



1051 / 1052 – 2007-PRESENT, MERCEDES SPRINTER, ADJUSTABLE 3.3 INVERTED RALLY STRUT INSTALLATION

Version 1.2

General Notes

- For the most up to date and current instructions, please visit our website at www.vancompass.com
- Please read all instructions thoroughly before starting installing Van Compass products.
- This is a bolt on performance damper that can be installed with simple hand tools.
- This shock kit can be completely removed, allowing the vehicle to be returned to an OEM strut configuration if desired.
- Note, if the vehicle has more than 50k miles on the OEM upper strut bushing, or the OEM strut bushing is showing significant wear, we strongly recommend replacing it with a new unit when installing the Van Compass Inverted Rally Struts.
 - OEM strut bushing part number: 906 323 05 20
- These instructions document installation on a 2023 AWD Sprinter 2500. Installation will be similar for older models as well as RWD models.
- The OEM bump stop can be retained but for optimum performance gains, we strongly recommend pairing the Van Compass Inverted Rally Strut system with the following supplemental front spring part numbers:
 - 4x4 / AWD:
 - VC Bump Buddies: 1043
 - Sumo Spring part number: SSF-327-47
 - RWD:
 - VC Bump Buddies: 1056 / 1057
 - Sumo Spring Part Number: SSF-106-40 / SSF-106-47
- The following instructions will document installation utilizing a digital angle finder to maintain similar alignment to what the vehicle currently has. **Regardless, the vehicle needs a professional alignment performed immediately after install.**

Parts List

1051 – 2007-PRESENT, MERCEDES SPRINTER 4x4 / AWD, ADJUSTABLE 3.3 INVERTED RALLY STRUT

- | | |
|-------------------------|--|
| • (2) 1051-01 | MERCEDES SPRINTER 4X4, ADJUSTABLE 3.3 INVERTED RALLY STRUT |
| • (2) 1009-03 | MERCEDES SPRINTER, FRONT STRUT BUSHING, LOWER RATE CUP |
| • (4) HM14-1.50-90-10.9 | M14-1.50 X 90MM LONG HEX HEAD BOLT, GR10.9 |
| • (4) NFSM14-1.50 | M14-1.50 FLANGED STOVER NUT |
| • (2) NFSM16-1.50 | M16-1.50 FLANGED STOVER NUT |

- (2) ABS-TAB ABS WIRING SENSOR TAB
- (2) BHM4-0.7-5 M4-0.7 X 5MM LONG BUTTON HEAD SCREW

1052 – 2007-PRESENT, MERCEDES SPRINTER RWD, ADJUSTABLE 3.3 INVERTED RALLY STRUT

- (2) 1052-01 MERCEDES SPRINTER RWD, ADJUSTABLE 3.3 INVERTED RALLY STRUT
- (2) 1009-03 MERCEDES SPRINTER, FRONT STRUT BUSHING, LOWER RATE CUP
- (4) HM14-1.50-70-10.9 M14-1.50 X 70MM LONG HEX HEAD BOLT, GR10.9
- (4) NFSM14-1.50 M14-1.50 FLANGED STOVER NUT
- (2) NFSM16-1.50 M16-1.50 FLANGED STOVER NUT
- (2) ABS-TAB ABS WIRING SENSOR TAB
- (2) BHM4-0.7-5 M4-0.7 X 5MM LONG BUTTON HEAD SCREW

Tools Needed

- Quality Jack and 2 jack stands.
- Simple hand tools:
 - Basic wrench and socket set:
 - Metric sizes: 13mm, 18mm, 21mm, 24mm
 - T-25, 2.5 & 7MM allen
- Flat nose screwdriver
- Electric or Pneumatic Impact gun recommended.
- Digital angle finder

Approximate Installation Time

- Professional shop with automotive lift: 1-2 hours (4-6 hours if trimming old shock mounts)
- Driveway install with jack and jack stands: 3-4 hours (6-8 hours if trimming old shock mounts)

Auxiliary Bracket Inspection / Modification:

1) CHECK BEFORE STARTING INSTALLATION OF STRUTS!!

- If the vehicle is equipped with an auxiliary shock kit; Upper shock brackets built before 10/1/2022 **will interfere** with the 3.3 Adjustable Inverted Rally Strut. 4x4 vehicles equipped with older brackets will require clearance modification of the existing brackets, or new upper shock brackets to be installed.
- Upper shock brackets built after 10/1/2022 **are designed to work** in conjunction with the 3.3 Adjustable Inverted Strut.
- Vans equipped with a 2" Striker lift kit **do not have any** clearance issues with any revision of upper shock brackets.
- Please see the images below denoting the difference between an older bracket (not compatible) and a current bracket (compatible with 3.3 Struts).

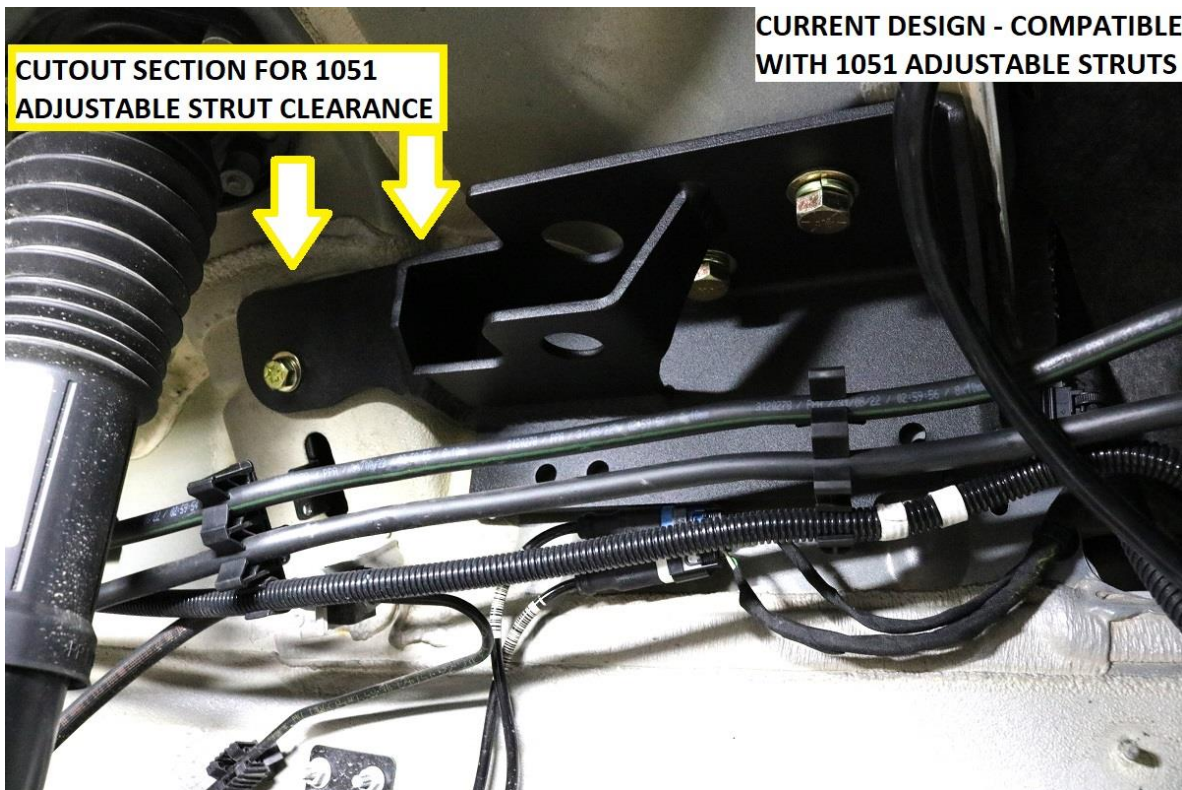

- 2) There are two options if the van is equipped with an older non-compatible bracket.
 - a. Remove and replace with the updated brackets. Van Compass part number: 7042-UPPERS
 - b. Remove and modify older designed brackets for compatibility with 1051 adjustable struts.
- 3) To modify older design brackets, reference the drawing below. Measure 6" forward from rear edge of bracket and 1.50" for the rectangular cutout that needs to be removed.

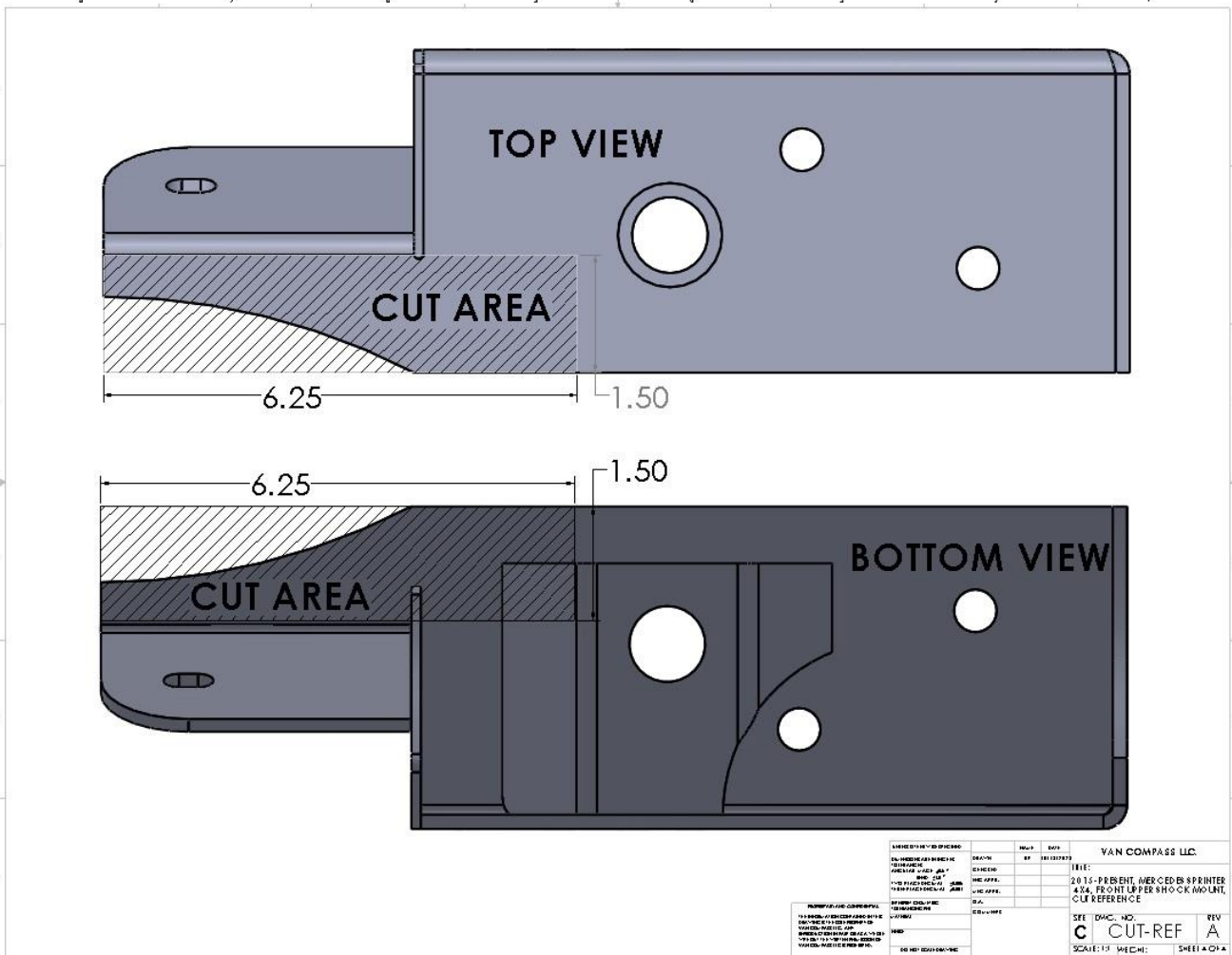

- 4) Cut the bracket as shown above using a 4-1/2" angle grinder or similar cutting tool.
 - a. Clean up any rough cut edges with a sanding disc.
 - b. Paint any exposed areas of metal prior to re-installation with a quality paint to prevent corrosion.
 - c. Re-install the bracket in the same manner it was removed. Reference Van Compass Instructions [7042](#) for re-installation process.

Strut Installation:

- 1) Installation will mainly document driver side. Installation on the passenger side is identical, any specific differences will be denoted in the instructions below.
- 2) Begin by gaining access to the upper strut mounting points in the cabin. On the driver side, locate and remove the two T25 torx screws which secure the floor mat cover to the door sill.
 - a. Remove the plastic trim piece under the torx bolts and remove the driver side floor mat. Note, it is helpful to have the seat slid all the way back for floor mat removal.



- 3) The passenger side upper strut bolts can be accessed by pulling up the tool kit cover panel in the passenger footwell. Use a large flat blade screwdriver to rotate the lock knobs on the kick panel so they are horizontal.
 - a. Remove the kick panel. See image below for reference.

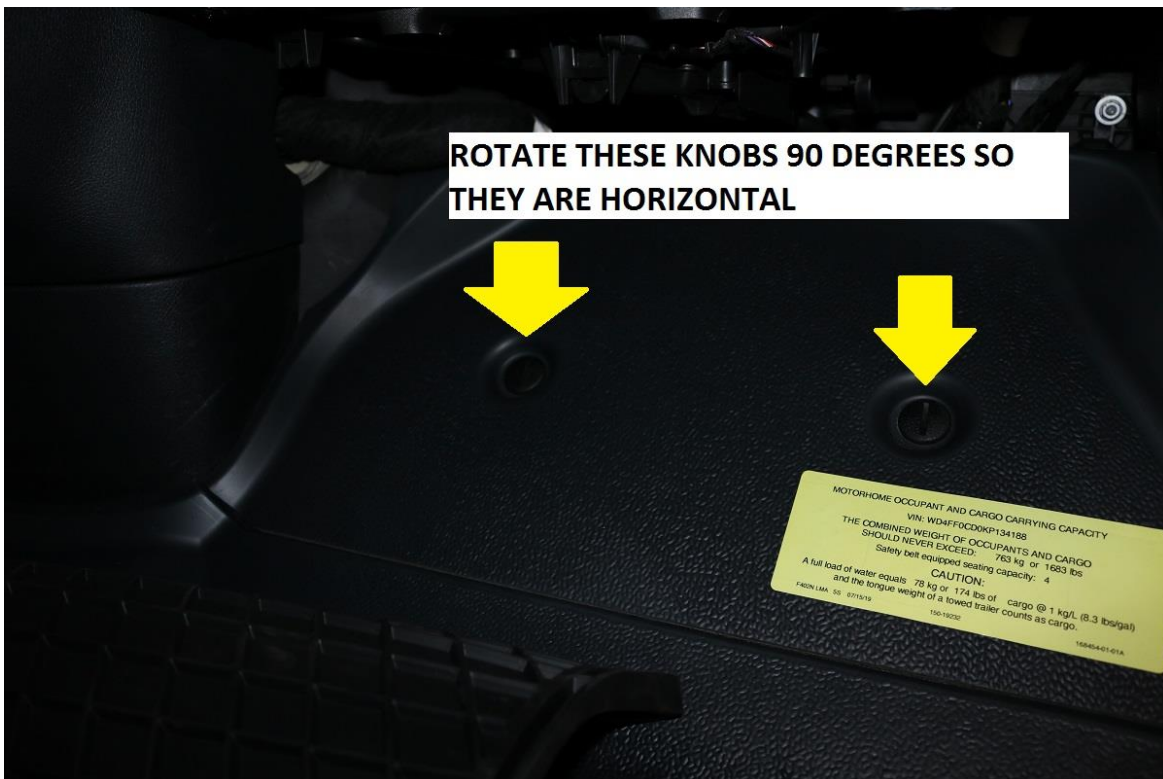

- 4) With the kick panel removed, remove the tool kit by pulling the back edge of it out from under the floor mat.
 - a. Once the back edge is out from underneath the rubber floor, slide the tool kit back until it clears the mounting tabs near the firewall. See image below for reference.

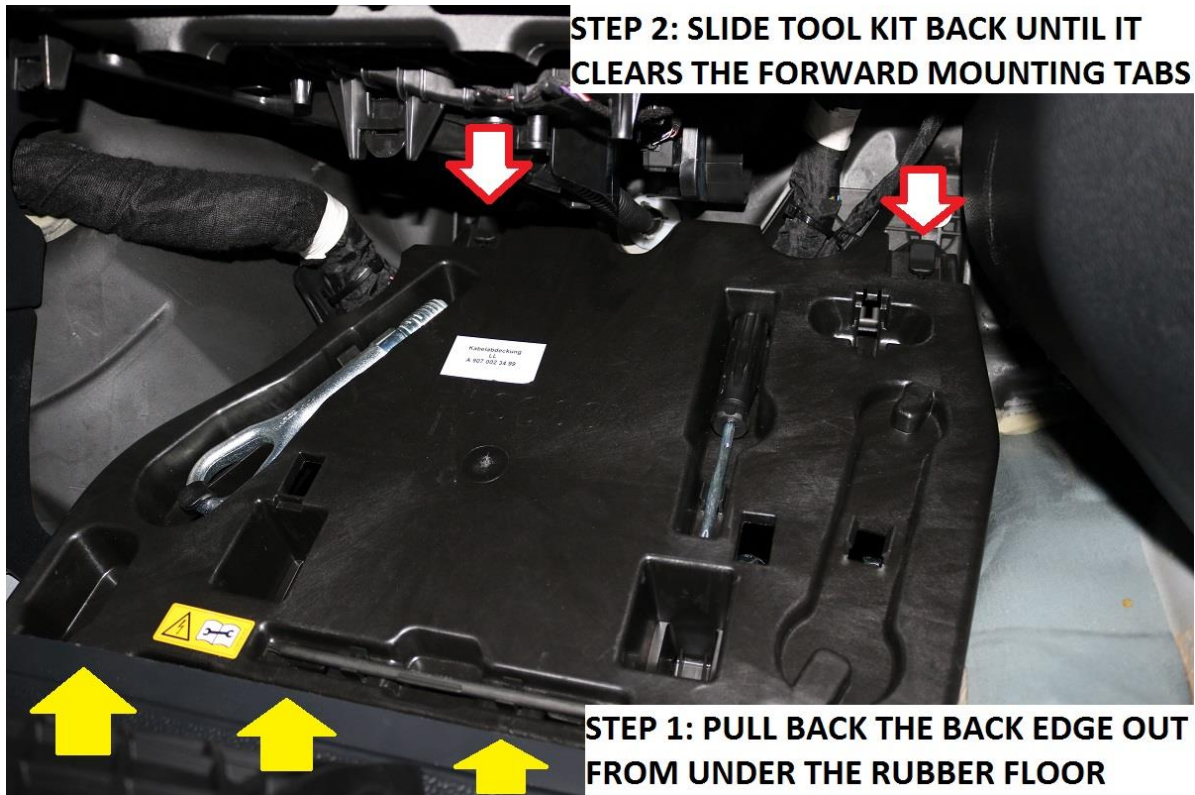

- 5) Jack the vehicle up and safely support it so the front suspension can hang free.
- 6) With the front suspension hanging free, remove the front wheels / tires. Factory lug bolts are typically a 19mm bolt head.
- 7) These instructions will show installation on the driver's (left hand) side of the vehicle. Installation on the passenger side is similar. Any differences will be addressed in the following instructions.
- 8) Remove the ABS sensor clip from the strut. Pull the locking tab towards the strut body and slide the clip upwards to free it from the strut.

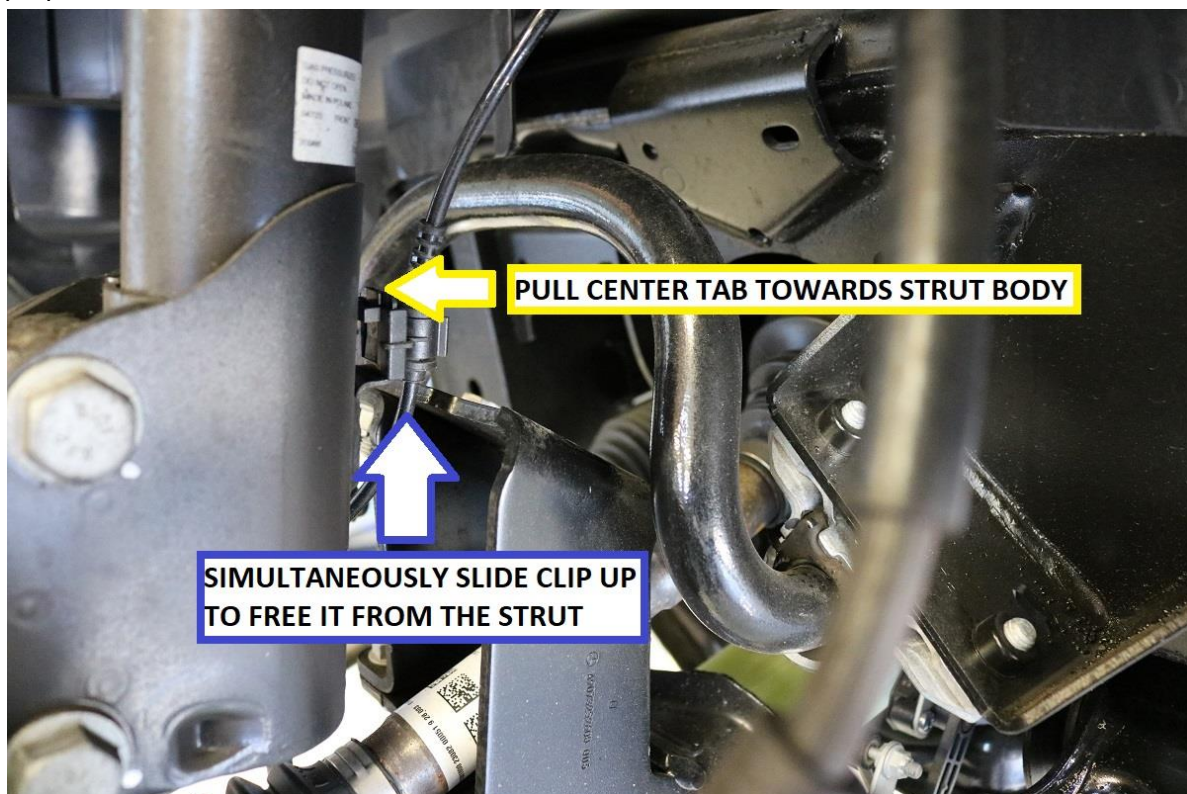

- 9) Use a digital angle finder and zero it to the flat of the lower suspension crossmember.
- Once zeroed, record the angle which the rotor face is showing. Measure and record both driver and passenger sides.



ZERO ANGLE FINDER ON FLAT OF SUSPENSION CROSSMEMBER

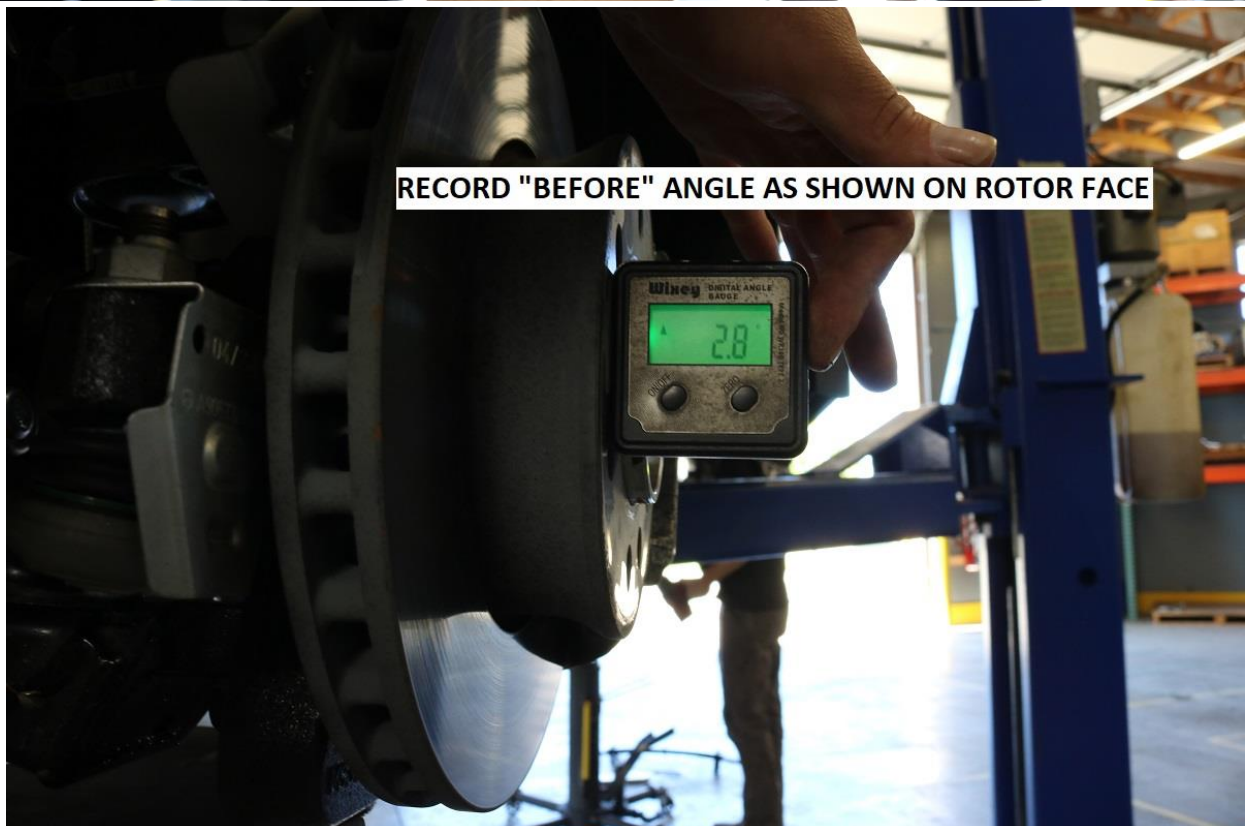

RECORD "BEFORE" ANGLE AS SHOWN ON ROTOR FACE

- 10) With the “before” camber measurements recorded, support / raise the lower control arm about 3/8” (10mm) to remove tension from the strut. Use a 21mm socket to remove the 2 bolts securing the strut to the steering knuckle.

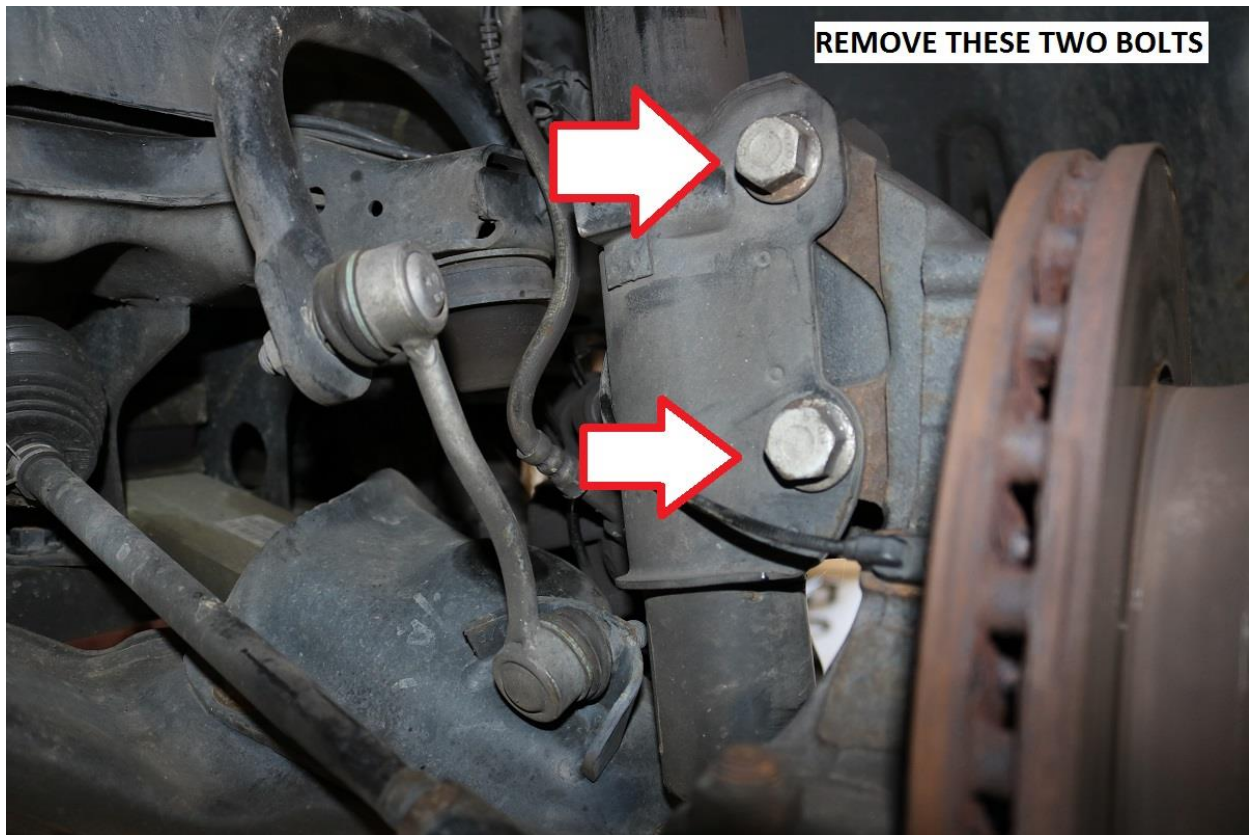

- 11) With the strut disconnected from the steering knuckle, allow the lower control arm to hang free again. Be careful to slowly lower the knuckle out of the strut. Be sure the wheel speed sensor wire and brake hose are not strained.



- 12) Fully remove the strut by removing the four upper strut bolts inside the cabin of the vehicle. Use a 13mm socket / wrench for removal.

- a. Note; it is helpful to have one person hold / remove the strut while another person removes the four bolts from inside the vehicle to prevent the strut from falling to the ground or causing damage to the CV boots on 4x4 models.



- 13) Place the strut on a work bench and remove the upper strut nut. Use a 24mm wrench with a 7mm allen to hold the strut shaft if an impact gun is not available.
- a. The preferred method of removing the strut nut is to pull the OEM strut boot down and hold the shaft by hand or with some soft jaws in a vice. Use a 24mm socket and impact gun to remove the nut.



- 14) Once the strut nut is removed, take careful inspection of the OEM strut bushing. If the vehicle has more than 50k miles on the strut bushing, we recommend replacing it at this time. If there are any cracks or tears in the rubber, we also recommend replacing it at this time.
- 15) The struts are driver and passenger side specific. They are labeled on the strut body and also feature a D (for Driver) or a P (for passenger) machined into the top cap.
- 16) Fit the 1009-03 lower rate cup to the new strut upper stud. The dished portion of the cup should face up towards the bushing. Fit the bushing to the stud followed by the OEM top out washer and new stover nut. See image below for reference.

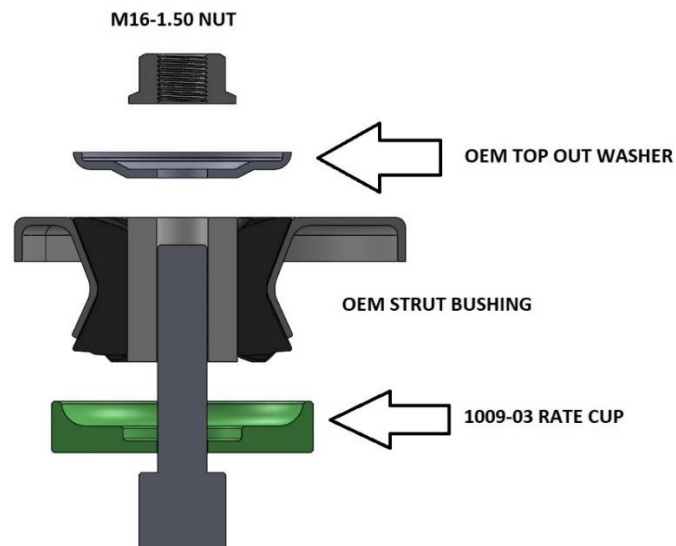

- 17) Lay the strut flat on a table as shown below.
 - a. Align the 2 wide spread bolts of the strut bushing with the flat on the outer surface of the 3.3 adjuster.

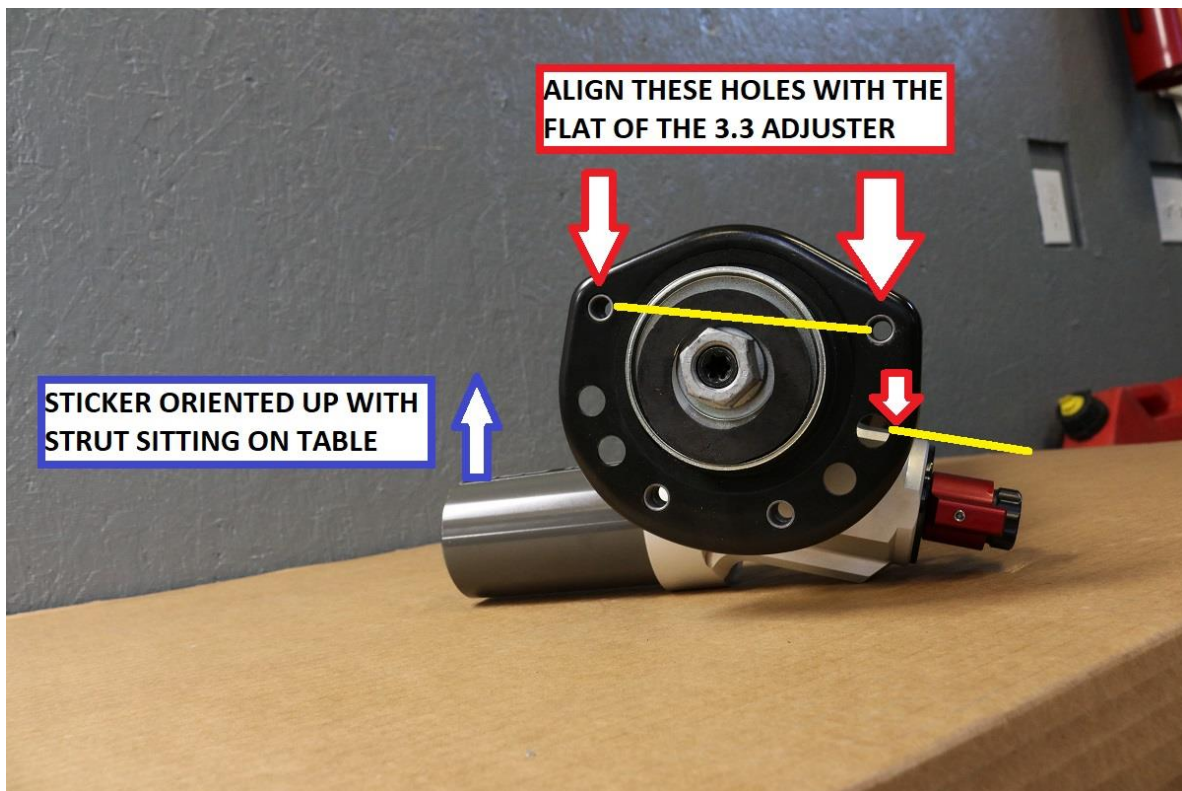

- 18) With the rate cup system installed and strut bushing aligned properly, torque the strut nut to 74 ft-lbs (100 N.m)
- 19) Install the ABS wiring clip to the strut. Use the included M4-0.7 allen bolt and 2.5mm allen wrench to secure. Install the ABS clip so the square hole is at the top and it jogs away from the strut body.



- 20) Support the lower control arm (LCA) / steering knuckle and fit the assembled strut to the vehicle.
- Again, make sure the correct strut is being installed on the correct side of the vehicle.
 - The reservoir should be oriented towards the rear of the vehicle, the 3.3 adjuster should be oriented towards the front.

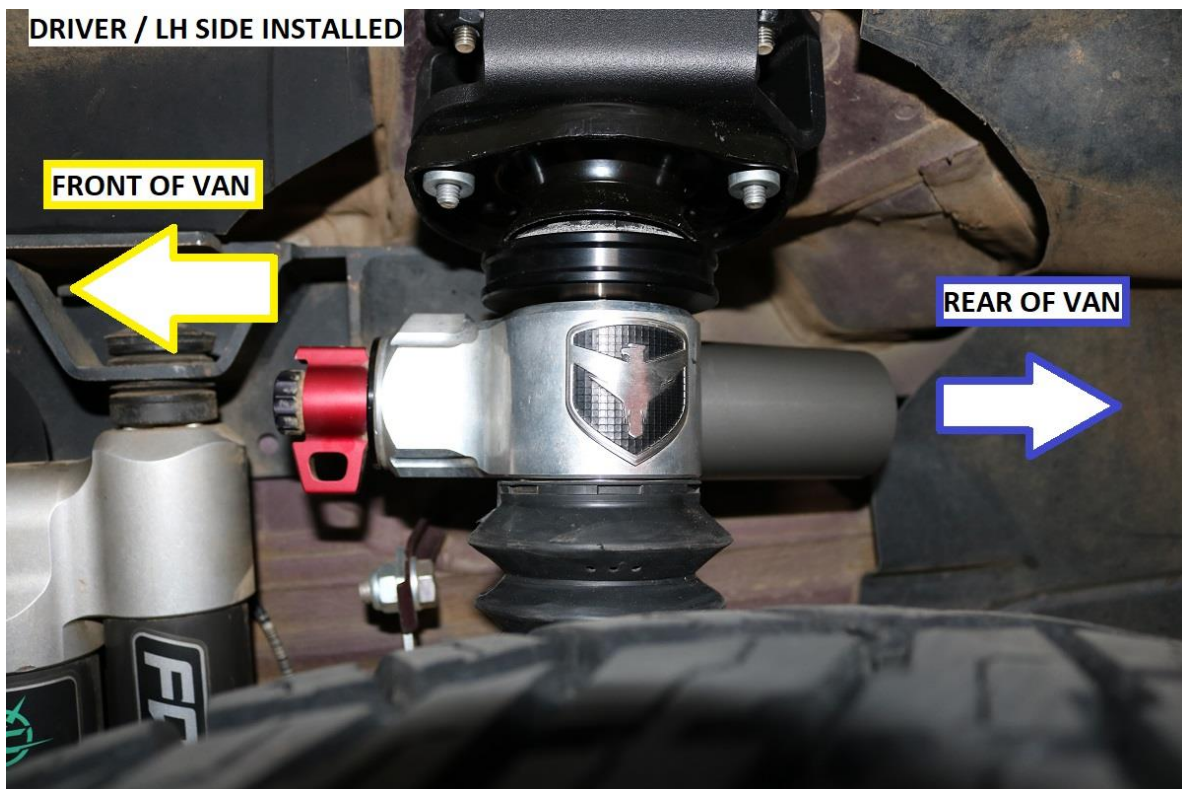

- c. Install the upper strut bolt to hold the strut in place and prevent it from sitting on the CV boot on 4x4 / AWD models.

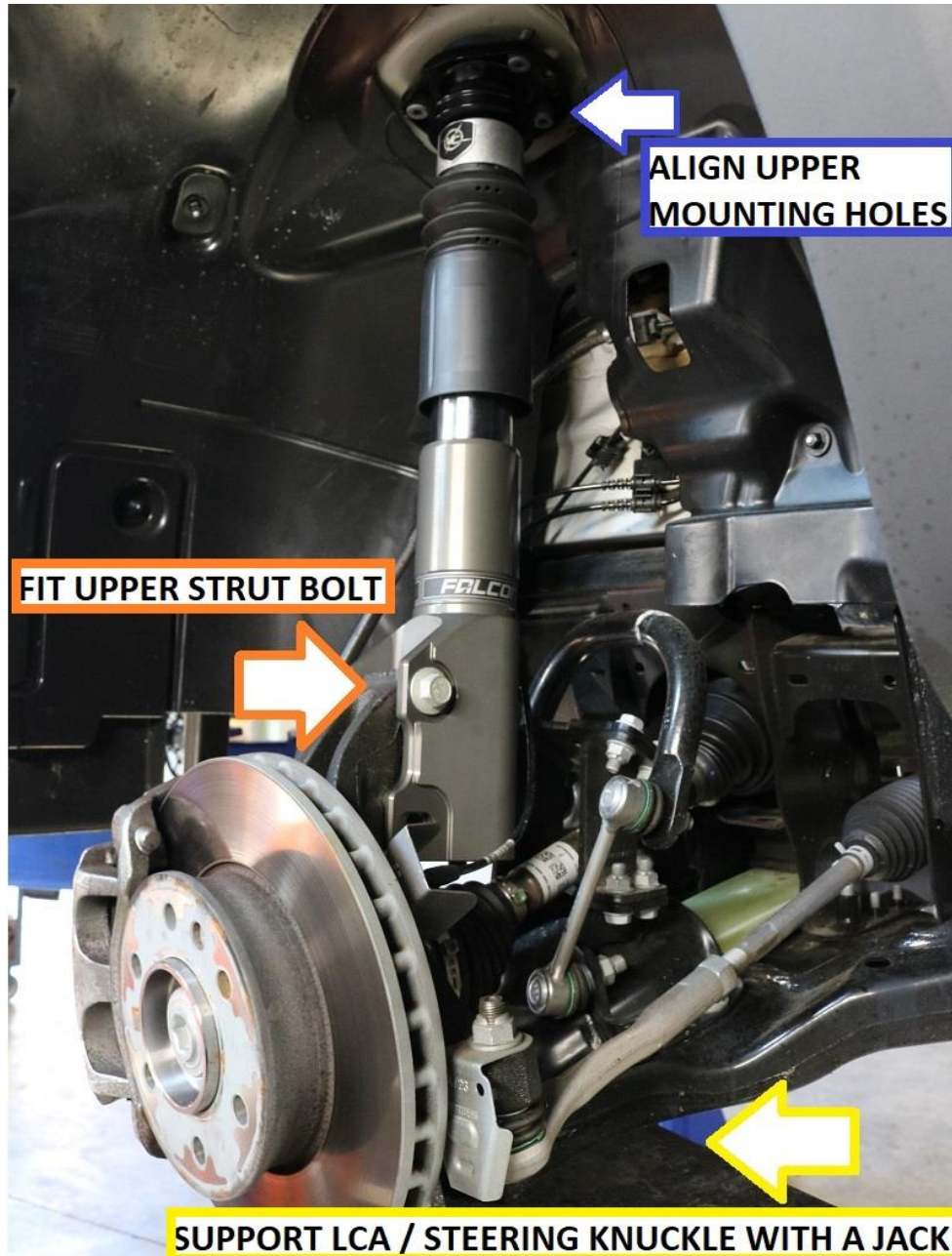

- 21) With the upper bolt fitted, rotate the top of the strut to align the mounting holes in the body.
- 22) Once upper mounting holes are closely aligned, jack the lower control arm up to the point where the OEM bolts can be re-installed into the upper mount.
- 23) Start all 4 bolts before tightening. Once all 4 bolts have been started, fully tighten to 21 ft-lbs (28 N.m)
- 24) Lower the jack supporting the lower control arm. This should set alignment near neutral in the slot.
 - a. Most vans will end up with this slot landing neutral / centered on the hole for the steering knuckle. (AWD / 4x4 van shown. RWD vans feature the alignment slot in the upper hole)
 - b. Install the second lower strut bolt and fit the included flange nuts.

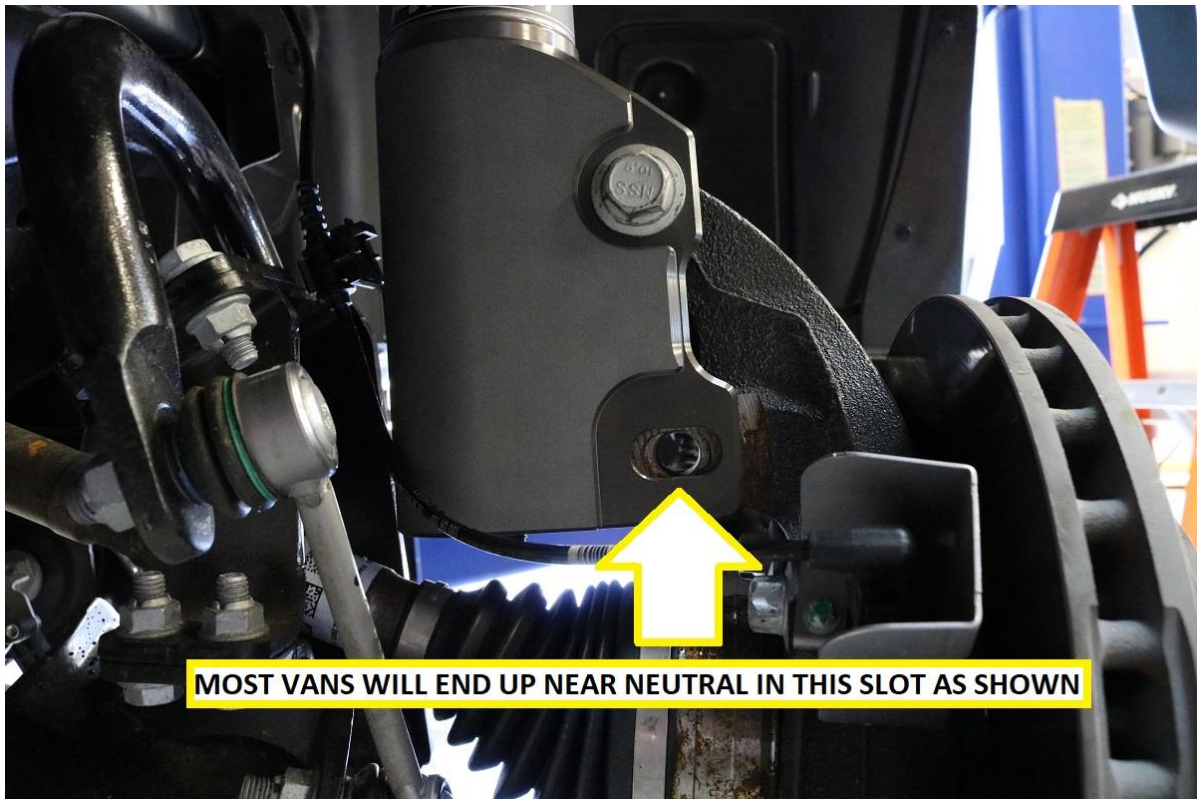

- 25) With the lower strut bolt installed, snug both upper and lower strut bolts. Use a 18mm wrench for the bolt head. 21mm wrench for the nut.
- Reference your camber degree measurements recorded in step 9.
 - Re-zero the angle finder at the same location as before.
 - Position the angle finder to the rotor in the same location / manner as before.
 - Match the camber angle measurement recorded previously and, fully tighten both upper and lower strut bolts.
 - Torque strut bolts to 127 ft-lbs (172 N.m)
- 26) Clip the OEM ABS wiring clip & wiring onto the strut in the same manner as it was attached to the OEM strut.
- Note; On 4wd / AWD vans, the OEM ABS clip may have an interference when running a supplemental spring like a Sumo Spring or Van Compass Bump Buddy due to the increase Jounce stop and large inverted rally strut body.
 - If there is contact at droop with the Jounce, remove the wires from their plastic retention clip and secure to the ABS tab on the strut via zip ties. See image below for reference.

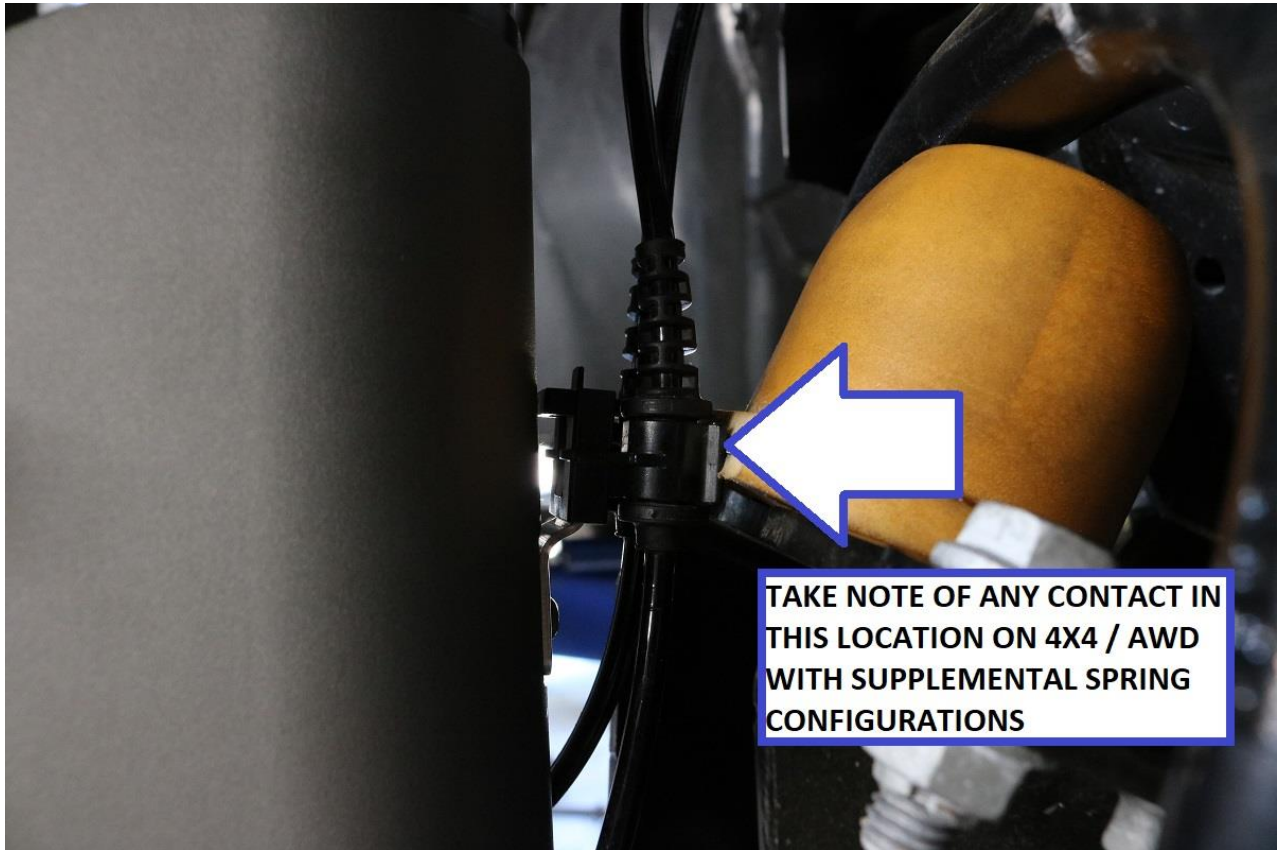

27) Repeat installation on the passenger side.

28) Re-install wheels and tires and lower van to ground. OEM torque spec for wheel studs are as follows:

- a. 2500 SRW: 177-187 ft-lbs (240-250 N.m)
- b. 3500 DRW: 140-150 ft-lbs (190-200 N.m)

CRITICAL POST INSTALL NOTES:

29) Double check adequate clearance of the reservoir to the body of the van as well as the 3.3 adjuster if the vehicle is equipped with the auxiliary shock brackets.

- a. Slight rotation of the strut can be performed by simply grabbing the reservoir of the strut and rotating it in or out for proper clearance.

30) Additionally, check tire clearance to the strut boot once the vehicle is sitting on the ground at ride height.

- a. If clearance is not sufficient, a wheel spacer may be needed to ensure the dust boot is not damaged.

31) Immediately perform a proper vehicle alignment before extensive driving.

32) Re-check all bolt torques after 100 miles of driving.

Installation is Complete

RELEASE OF LIABILITY

I, the customer, do hereby release and forever discharge Van Compass LLC their agents, employees, successors and assigns, and their respective heirs, personal representatives, affiliates, successors and assigns, and any and all persons, firms or corporations liable or who might be claimed to be liable, whether or not herein named, from any and all claims, demands, damages, actions, causes of action or suits of any kind or nature whatsoever,

whether known or unknown, fixed or contingent, which I now have or may hereafter have or claim to have, as a result of or in any way relating to the following: Parts sold & installed by Van Compass LLC or parts sold & installed by end-user; any parts sold online, any parts sold online or installed by a re-seller, any parts installed by an installation shop.

It is understood and agreed that this payment is made and received in full and complete settlement and satisfaction of the aforesaid actions, causes of action, claims and demands; that this Release contains the entire agreement between the parties; and that the terms of this Agreement are contractual and not merely a recital. Furthermore, this Release shall be binding upon the undersigned, and his respective heirs, executors, administrators, personal representatives, successors and assigns. This Release shall be subject to and governed by the laws of the State of Idaho.

PRODUCT SAFETY WARNING:

Van Compass LLC strongly recommends the installation of products be done by a certified mechanic. If this does not occur, be certain the person(s) installing the product read, understand and follow all instructions and warnings pertaining to the application before installation. Do not add, alter, or fabricate any factory or aftermarket parts to increase vehicle height over the intended height of the Van Compass LLC product purchased. Mixing component brands is not recommended.

Installation of suspension lift kits or any other lifting kits or devices will raise the center of gravity. For this reason, Van Compass LLC urges that extreme caution be used when encountering driving conditions which may cause vehicle imbalance. Furthermore, the driver's field of vision and judgment will not be as good due to the height of the vehicle. Due to the installation of larger tires, the speedometer will read slower than the actual speed being traveled and more distance will be required to stop the vehicle. It is the owner's responsibility to caution and warn any potential driver of the vehicle about these driving and handling conditions. Van Compass LLC will not be held liable or responsible for damages or personal injuries resulting from the use of lifting devices and or related products. The tires and rims should be changed to sufficiently increase the vehicle's total overall width and stability to help accommodate lifting devices.

Van Compass LLC aftermarket suspension products and accessories modify a vehicle for uses which exceed conditions anticipated by the vehicle manufacturer. The uses include the high performance demands required during off-road. These conditions vary in the degree of extremity and cannot be controlled by the vehicle or product manufacturer. If the components within the suspension system or accessories become worn due to frequent and/or extreme use, the safety and reliability of the vehicle is at risk. The maintenance of aftermarket equipment to ensure the vehicle occupants safety is entirely your responsibility. Do not purchase Van Compass LLC products unless you are willing to accept this responsibility. Do not install any Van Compass LLC suspension products or accessories unless you feel competent at installing the product without causing present or future injury to yourself or other vehicle occupants; seek an authorized installation center.

Most states have some type of law limiting vehicle height. The amount of lift allowed, and how the lift can be achieved, varies greatly. Several states offer exemptions for farm and commercial registered vehicles. It is the vehicle owner's responsibility to check state and local laws to ensure that their vehicle will be in compliance. Van Compass LLC reserves the right to make changes in design, materials and specifications as deemed necessary without prior notice and without assuming obligation to modify any product previously manufactured. Obligation or liabilities will not be assumed with respect to similar products previously advertised.

This Release of Liability and Product Safety Warning has been read and fully understood by the undersigned and has been explained to me.