



BISON 2000A OWNER'S MANUAL

Preface

Thank you for purchasing the BISON 2000A Air heater. This instruction book describes the structures, working principles, installation and operation of the BISON 2000A. For correct use of the heater, please read this instruction book carefully before installation and use. The instruction book should be saved in a convenient place for reference later.

Note

- This instruction book is subject to revision without notice, but the instruction book is in conformity to the purchased product.
- Our effort is to explain all questions you may have. If you have any doubts or find anything incorrect in this manual, please contact us directly.
- Check the heater for any damage when unpacking and contact the dealer immediately if anything is found.
- If any troubles arise during application, please contact General Components or other customer service stations authorized by this company. We shall do our best to provide service to you.

Comply with the operation manual for installation and use, to ensure prolonged and reliable operation.

Contents

Introduction	5
Technical Data.....	6
BISON 2000A Internal Structure.....	7
Structures and Working Principles.....	8
Case Assembly.....	9
Installation	10
Installation of the Main Heater Body.....	12
Air Inlet & Outlet.....	14
Additional Ducting (Optional)	15
Installation of Combustion Air Pipe and Exhaust.....	16
Fuel Lines.....	18
Fuel Standpipe	21
BISON 2000A Wiring Diagram – Brushless Version.....	23
Timer and Rheostat Control Plugs	25
Wiring Loom Plug for Timer and Rotary Control	26
Circuit Interfaces.....	27
Operation	28
Rheostat Control	28
Mini Timer.....	29
Manual Start Up and Shut Down	30
Pre-setting Heating Time	30

Pre-setting Starting and Heating Times	30
Checking Temperature.....	31
Converting to Thermostatic Mode.....	31
Fault Information	31
Remote Operation	32
Installation Fuel Priming Feature	32
LCD Digital 7-Day Timer	33
Changing Language	34
Changing the Date and Time.....	35
Manual On/Off.....	36
Switching to Thermostatic Mode.....	37
Fan Mode	37
Pre-setting Heating Times.....	38
Installation Fuel Priming Feature	40
Checking Error Codes	41
Resetting Digital Controller to Factory Settings.....	42
Maintenance	43
Fault Codes.....	44
Rheostat Control	44
Fault Codes.....	44
Timers.....	45

Introduction

The main equipment of the BISON 2000A air heater (hereinafter referred to as 'the heater') is a small fuel furnace controlled by a single-chip micro-processor. Its furnace body (the heat exchanger) is located in the hood shaped case, which serves as an independent air passage. Cold air is drawn into the air passage by the fan and blown out when it becomes hot.

The heat can be supplied by the heater to the driver's cab and passenger's compartment independently from the engine. The schematic diagram is shown in Fig I.

The heater is fully automatically controlled. It features a compact structure, easy installation, low running costs, easy maintenance and is safe and reliable.

1. Control switch
2. Heater Body
3. Fuel Pump
4. Wiring Harness
5. Vehicle's Battery
6. Vehicle's Fuel Tank
7. Exhaust Pipe
8. Combustion Air Intake

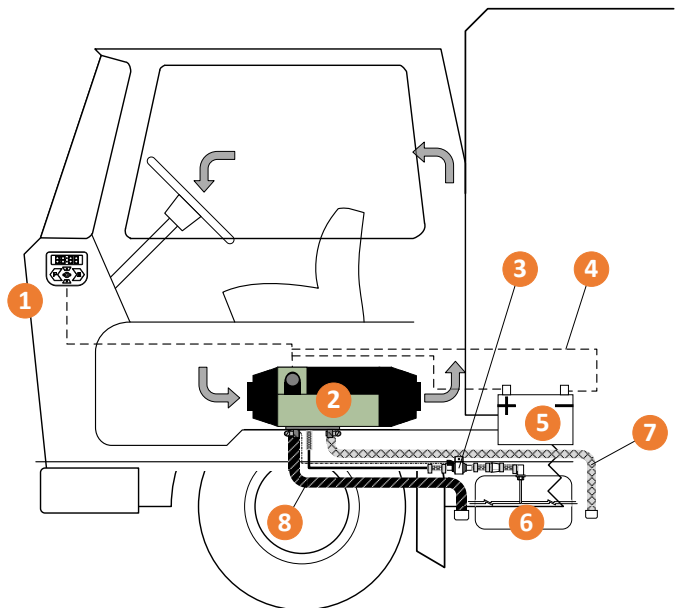

Figure I

Technical Data

Output (w)	2000	
Fuel	Petrol	Diesel
Voltage	12/24V	12/24V
Fuel Consumption (l/h)	0.14 - 0.27	0.12 - 0.24
Power Consumption	14 - 29	
Working Temperature	-40°C - 20°C	
Weight (KG)	2.6	
Dimensions (mm)	323x120x121	

Variable Output	Current Draw
Position	(Amps)
PO1	0.9
PO2	1.1
PO3	1.2
PO4	1.3
PO5	1.5
PO6	1.7
PO7	1.9

BISON 2000A Internal Structure

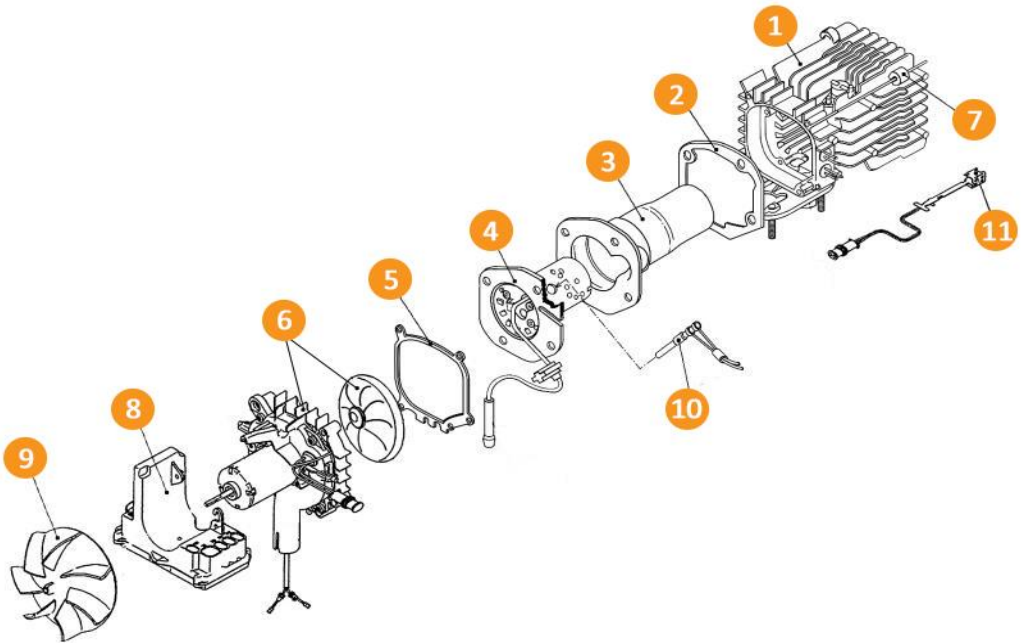

Figure II

- | | |
|------------------------------|------------------------------|
| 1. Heat exchanger | 2. Gasket 1 (4 hole) |
| 3. Combustion chamber | 4. Burner Assembly |
| 5. Gasket 2 (5 hole) | 6. Air Motor Assembly |
| 7. Insulating bush | 8. ECU |
| 9. Air Fan Wheel | 10. Glow Pin |
| 11. Overheat Sensor | |

The heat exchanger is made of die-cast aluminium, with radiating fins around the rear. The combustion chamber fits inside the inner cavity of the heat exchanger. The burner assembly and glow pin, fit into the end of the combustion chamber. Fuel comes to the burner assembly through the fuel pipe and is ignited by the glow pin. The flame is passed up the combustion chamber and returns between the inner walls of the heat exchanger and discharged through the exhaust outlet vent to the outside of the vehicle or boat.

The air supporting combustion of the furnace, comes from the combustion air inlet port and is sent down the combustion pipe by the combustion supporting air blades of the fan motor.

Structures and Working Principles

The structure of the main heater is shown in Fig. III

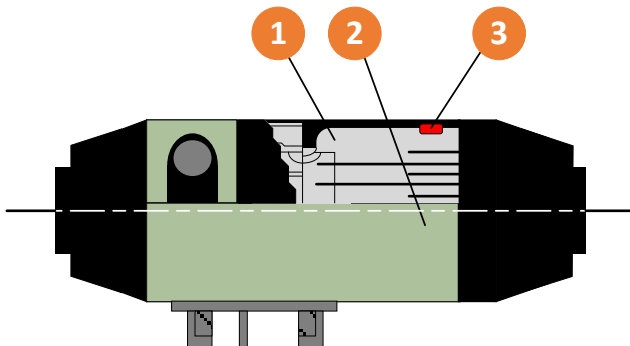

1. Heat Exchanger
2. Heater Case
3. Insulating Bush

Figure III

Case Assembly

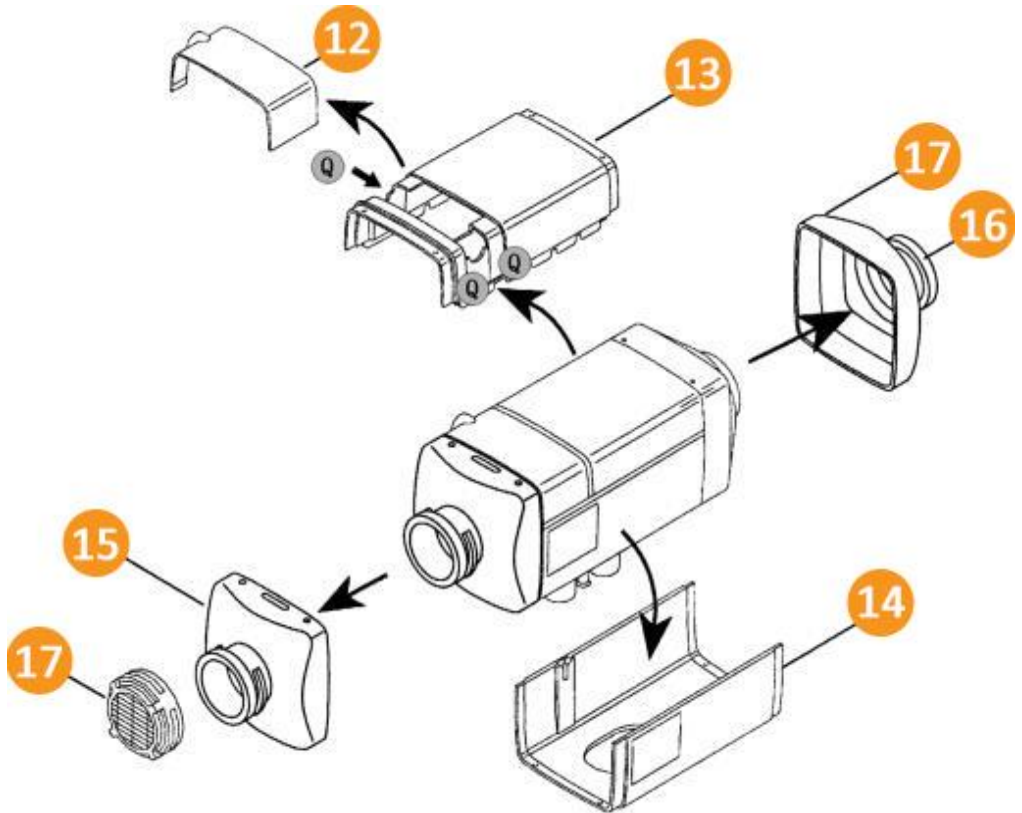

Figure IV

12. Junction box cover
14. Hot air outlet
16. Outlet Cover

13. Top Case
15. Inlet Cover
17. Grill

Installation

The kit includes everything necessary for installation.

Exploded Parts Diagram

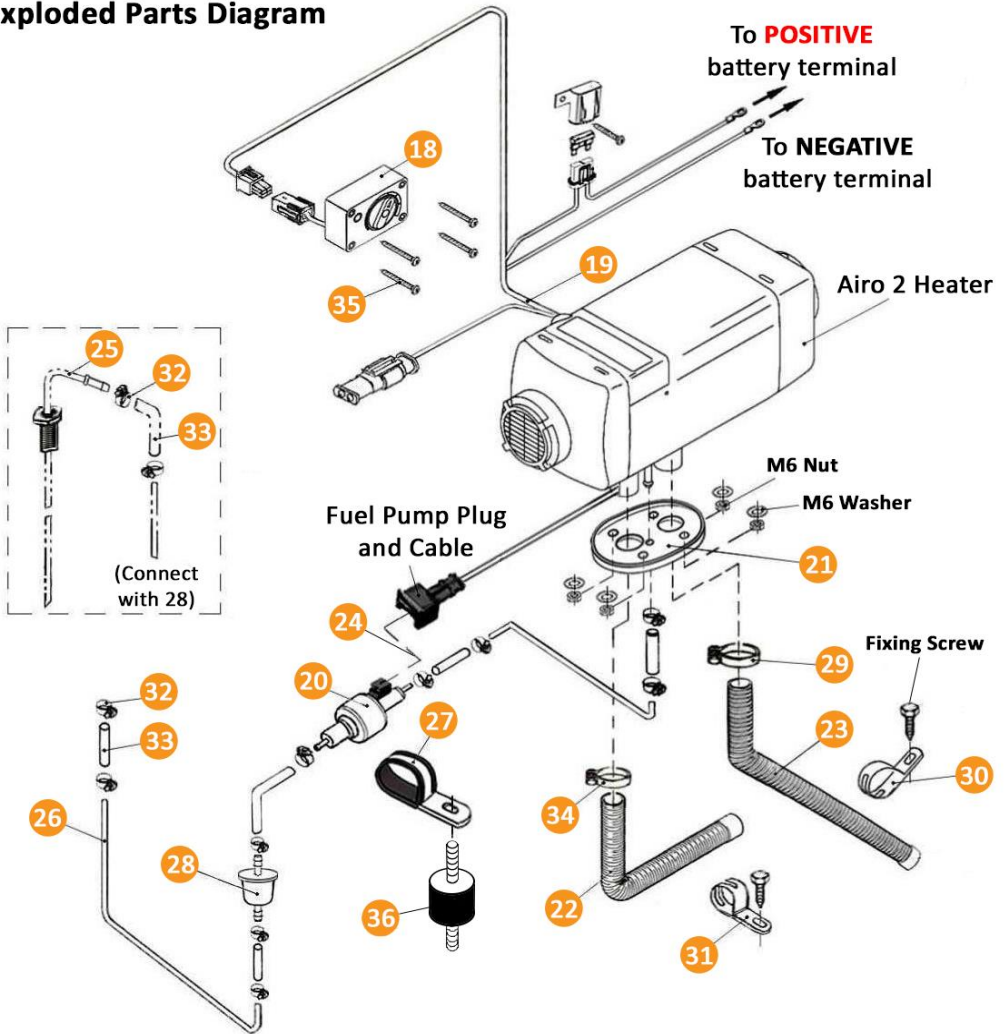

Figure V

- | | |
|-------------------------------|----------------------------|
| 18. Control Switch/Timer | 19. Main Wire Harness |
| 20. Fuel Pump | 21. Mounting Gasket |
| 22. Combustion Air Inlet Pipe | 23. Exhaust Pipe |
| 24. Fuel Pump Extension Loom | 25. Fuel Standpipe |
| 26. Fuel Pipe | 27. Fuel Pump Bracket |
| 28. Fuel Filter | 29. Exhaust Pipe Clip |
| 30. Exhaust Pipe Fixing Clip | 31. Air Inlet Fixing Strap |
| 32. Fuel Connector Hose Clip | 33. Fuel Line Connector |
| 34. Air Inlet Hose Clip | 35. Control Fixing Screw |
| 36. Anti-Vibration Mount (M6) | |

Figure V shows the diagram for installation. The position and ways of fixing of various parts may vary from one vehicle/boat to another, but the general principles remain the same.

Attention:

- Do not mount the heater near any flammable sources
- Do not install the heater in closed spaces without ventilation
- Do not place the heater near anything that can cause a blockage
- Do not mount the heater near any water sources and protect it from any splashing

Installation of the Main Heater Body

For the ease of servicing, fault finding and air flow it's recommended that the main body is placed in an area with easy access. Figure VI shows the minimum distances required.

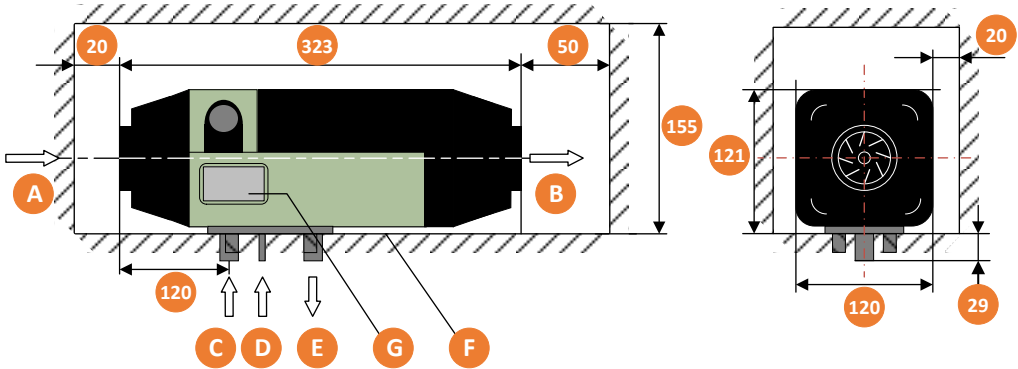

Figure VI

- | | |
|--------------------------------|---------------------------------|
| A. Air heating inlet | B. Air heating outlet |
| C. Combustion air inlet | D. Fuel inlet |
| E. Exhaust outlet | F. Non-interference area |
| G. Information label | H. Installation surface |
| I. Gasket | |

Choose a flat installation surface, any undulations could cause the case to twist and will not ensure an even mount. Make sure there are no foreign bodies between the bottom of the heater and the installation surface itself. This will ensure a good seal between the two. File down any drill holes to again ensure an even mounting surface. Tighten the M6 bolts provided to a torque setting of 6Nm+1Nm.

Figure VII shows the position of the installation holes. If the installation area is less than 1.5mm thick a mounting plate will be required (Figure VIII).

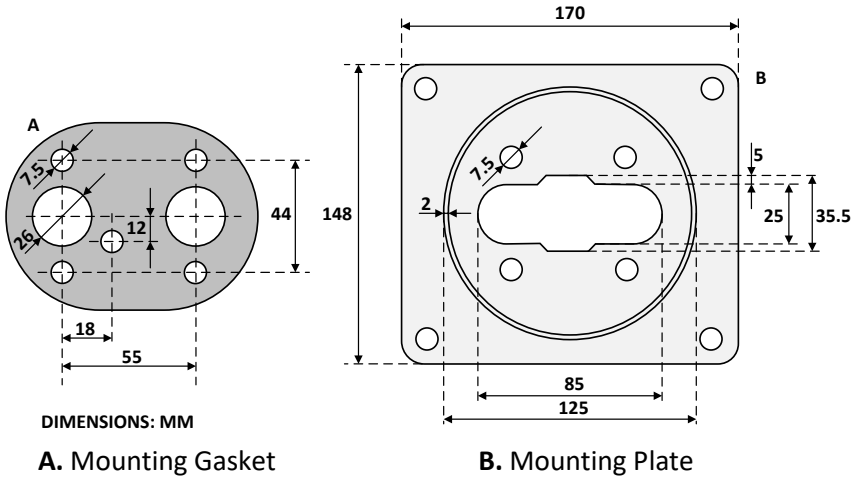

Figure VII

Figure VIII

If the heater is being reinstalled, a new gasket should be used.

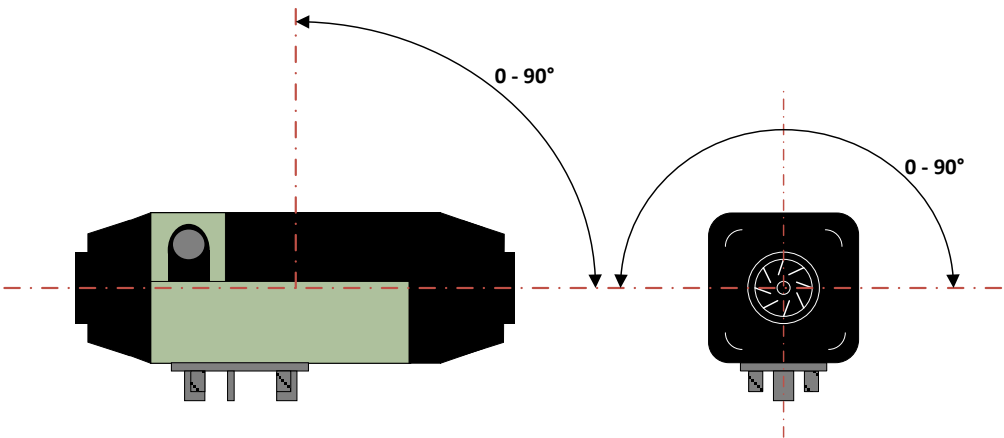

Figure IX

The direction of the heater for installation is shown in figure IX.

Ensure you do not exceed the inclination angle or normal operation will be affected.

After installation, make sure there is no friction between the fan and other nearby parts to ensure smooth operation and make sure the heater label is clearly visible for ease of maintenance in the future.

Air Inlet & Outlet

Make sure that the hot air outlet does not exit onto any parts affected by heat and that it isn't directed toward the flow of anything that can cause a blockage, near splashing water or near the vehicles exhaust.

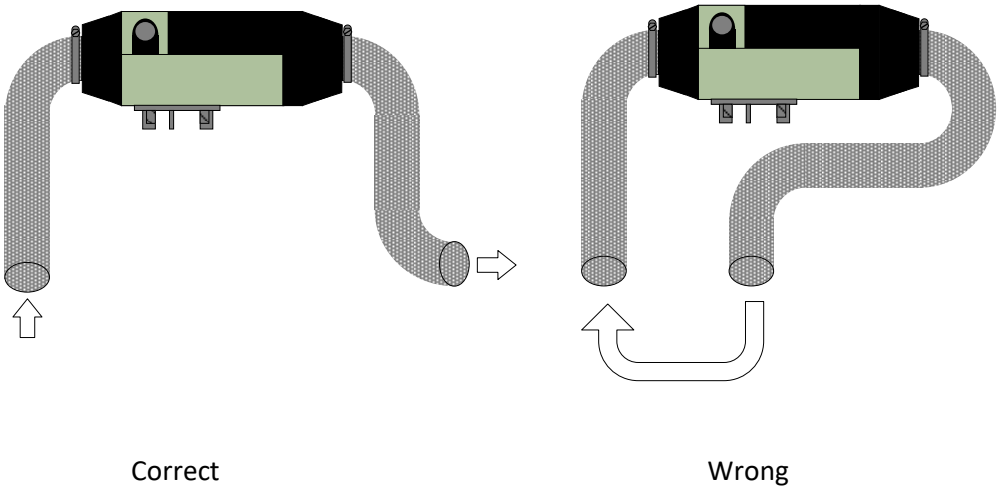

Figure X

Avoid re-entering of the supplied hot air into the inlet port (as shown in Figure X). If no inlet pipe is required, make sure the grill is installed at the inlet port instead (Figure IV no. 17).

Additional Ducting (Optional)

Quantity of ducting can be purchased according to

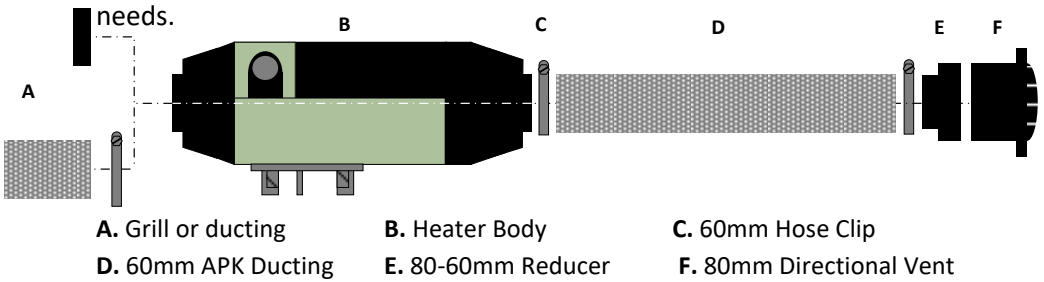
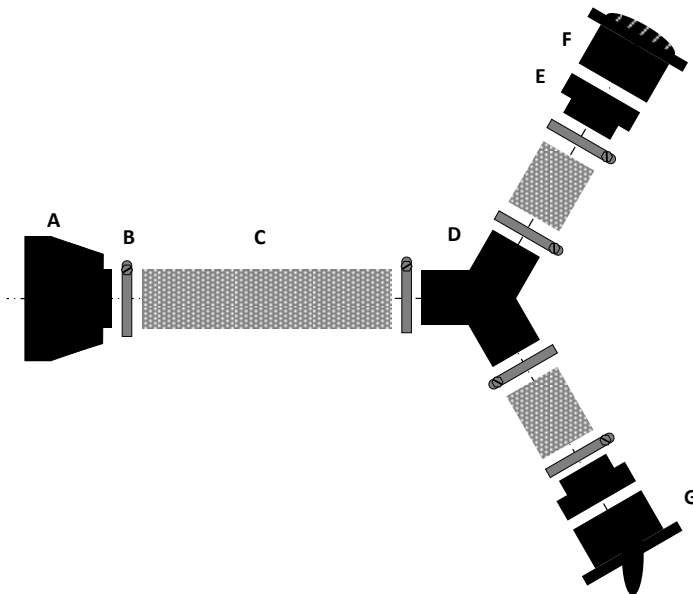

Figure XI



A. Heater Outlet **B.** 60mm Hose Clip **C.** 60mm APK Ducting **D.** 60mm 'Y' Branch **E.** 80-60mm Reducer **F.** 80mm Directional Vent **G.** 80mm Open/Close Vent

Figure XII

Installation of Combustion Air Pipe and Exhaust

The combustion air inlet pipe sucks in fresh air from outside of the vehicle and the exhaust discharges fumes outside of the vehicle. Measures must be taken to avoid the fumes from re-entering the vehicle.

The pipes should exit at the bottom of the vehicle, ensuring that the openings are far enough away from any splashing water or dirt that can clog them. Figure XIII shows the right and wrong way to install the pipework.

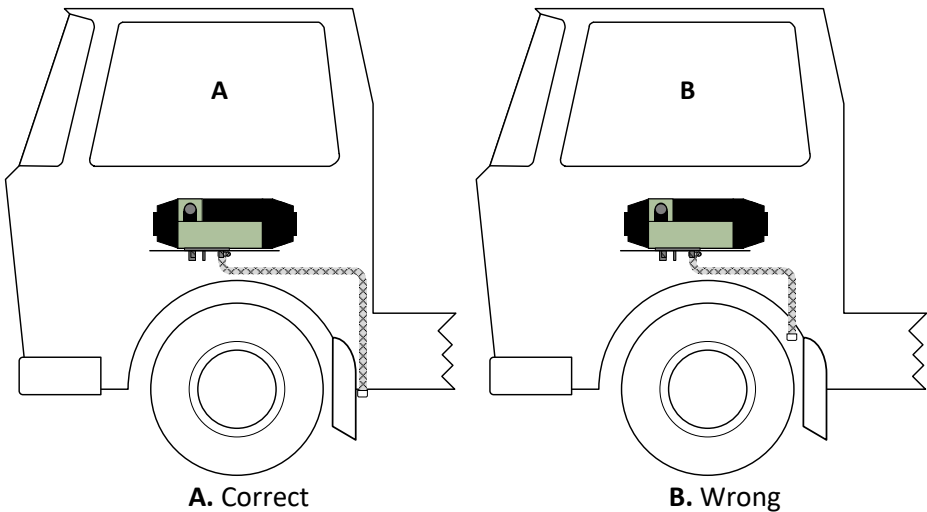

Figure XIII

Only use the inlet pipe and exhaust provided with the kit for installation. The exhaust pipe is made of corrugated stainless steel while the combustion pipe is aluminium covered in paper and plastic. **Do not** confuse the two. Use the supplied clamps to fix them securely to the combustion air inlet and the exhaust outlet on the heater. The protective end cap on the outlet of the

combustion air pipe and exhaust pipe should be kept in good condition. Do not damage or remove them.

Both the combustion air pipe and exhaust pipe should come downward from the heater and face opposite to the vehicle's direction of travel. If the pipe cannot avoid a curve, make sure the radius is no smaller than 50mm and the sum of all curves does not exceed 270°. Figure XIII shows the right and wrong way to install the combustion air intake. Note that it is the same for the exhaust too.

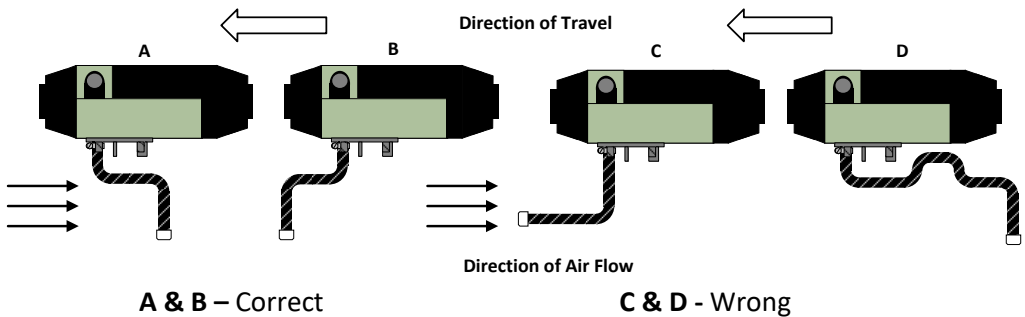

Figure XIV

When the heater is operating, the exhaust will get hot, so make sure it is installed away from any parts that could get damaged by high temperatures. The exhaust vent should also point downward to the road surface with an angle of $90^{\circ} \pm 10^{\circ}$. This is best achieved by fixing a clamp 150mm from the pipe end.

Any exposed exhaust should be covered with a heat shield to prevent scalding.

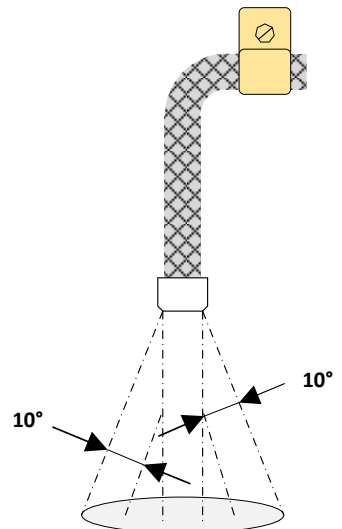

Figure XV

Fuel Lines

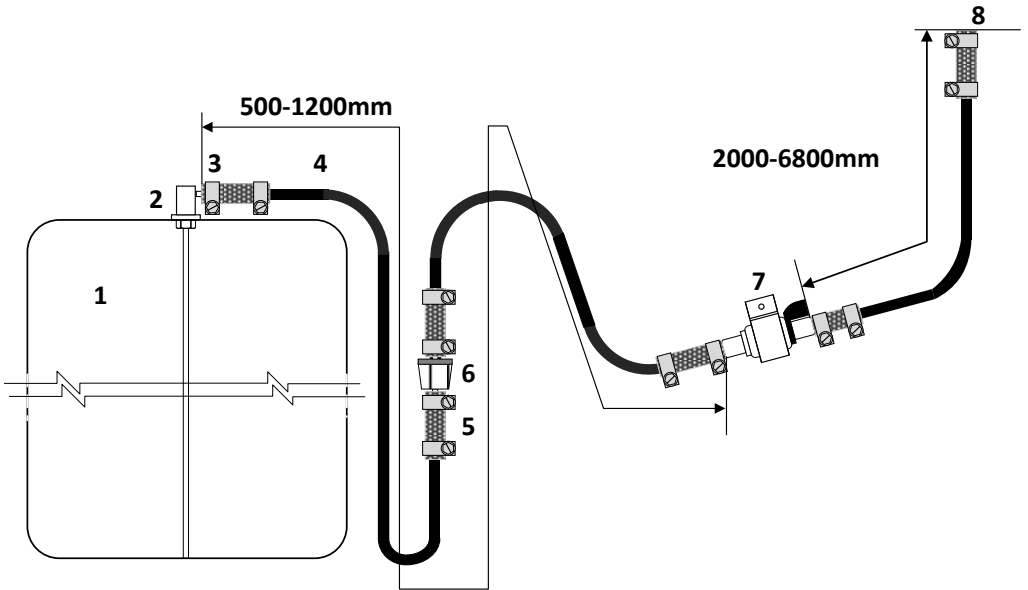
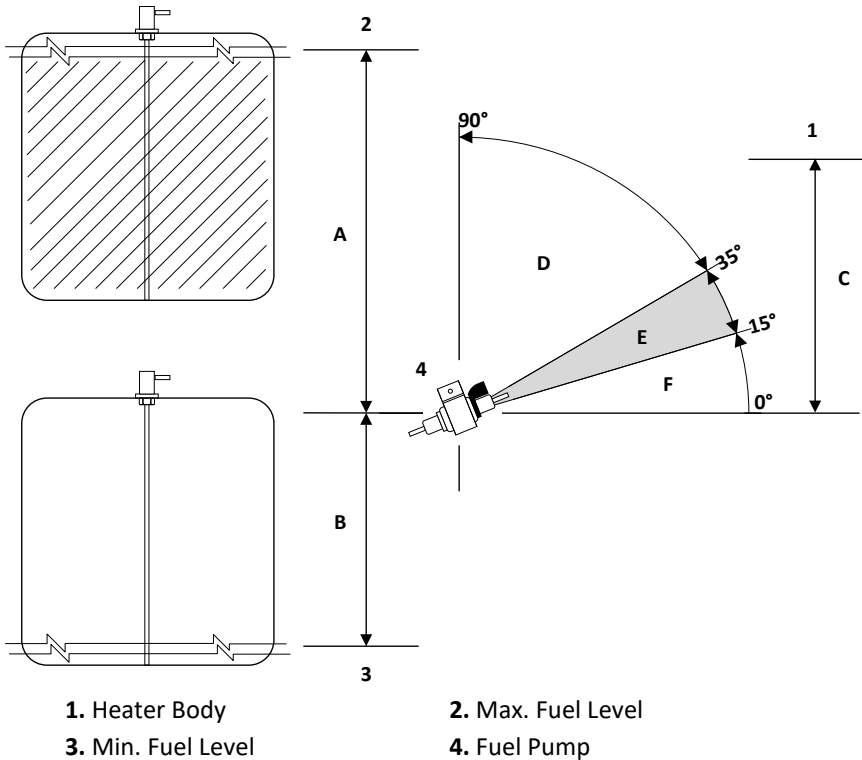

Figure XVI

- | | | |
|--------------|--------------------------|-------------------------|
| 1. Fuel Tank | 2. Fuel Standpipe | 3. Fuel line Hose Clamp |
| 4. Fuel Line | 5. Rubber Fuel connector | 6. Fuel Filter |
| 7. Fuel Pump | | 8. To Heater |

Always fit the fuel pump on the anti-vibration mount securely onto the vehicle. Ensure the outlet of the fuel pump tilts upward. The correct angle is shown in Figure XVII.

Where possible the fuel line is ideally placed uphill to the fuel pump to ensure ideal bleeding of the fuel line.



Fuel Pump Angle & Suction Height

- | | |
|--------------------------------|-------------------|
| A. 3000mm | B. 500mm |
| C. 2000m | D. Not acceptable |
| E. Acceptable (between 15-90°) | F. Not acceptable |

Figure XVII

Figure XVII shows the ideal way to mount the fuel pump

The fuel pump's outlet should tilt upward at an angle between 15°-35° (as shown above).

Only use the fuel line provided, ensure the pipe is placed away from any possible debris and avoid any sagging in the line. Make sure the fuel line does not flow downward toward the fuel pump. This will prevent correct fuel flow and produce air bubbles in the line.

The fuel filter, fuel pipe and clamps should all be replaced after 2 years of us

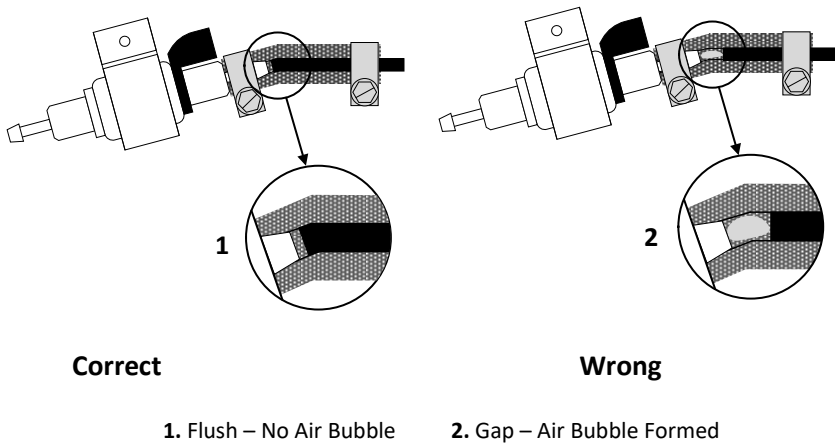

Figure XVIII

Figure XVIII shows the correct way to connect fuel lines to prevent the build-up of air bubbles. Ensuring they are flush and minimising bends.

When the fuel is being sucked from the vehicle tank, or an independent tank, a suction pipe is required. Make sure all the openings are appropriate for the installation and a tight seal is maintained for the base of the suction pipe.

The bottom of the suction pipe should be about 30-40mm from the bottom of the fuel tank so as to avoid sucking impurities or sediment from the bottom of the fuel tank.

Fuel Standpipe

A fuel standpipe (or suction pipe) will need to be installed in the vehicle's fuel tank or an independent fuel tank depending on what the installation calls for. Sealant is not required to fit the standpipes.

Depending on the standpipe provide in the kit you will need to install the standpipe in one of two ways.

Standpipe 1: (Part No: AHZ-034)

Figure XIX

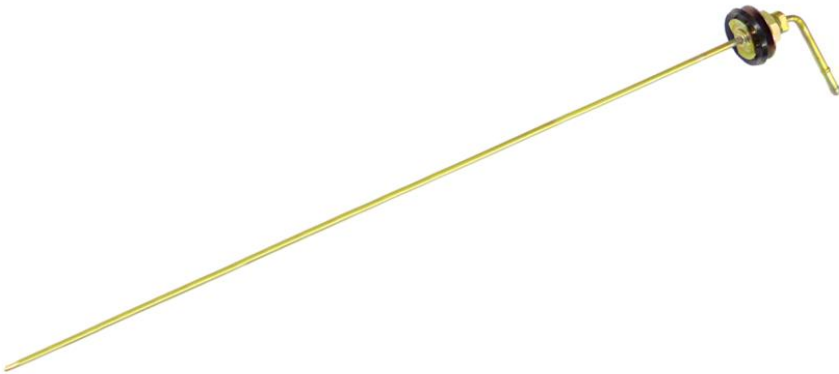

Usually supplied in Marine kits and supplied bent, this standpipe is installed like so:

- Drill a hole in the top of the vehicle's fuel tank $\Phi 22 \pm 0.2\text{mm}$ in size. Ensure it is smooth and clean of burrs
- Remove the top nut and washers and bend the standpipe straight
- Cut the standpipe down to size if necessary
- Fit the standpipe by tilting it into position into the newly drilled hole
- Place the rubber and metal washers back on top followed by the nut and tighten it securely on top

Stand pipe 2: (**Part No:** AHZ-035)

Figure XX



Supplied mainly in vehicle kits, this standpipe is installed like so:

- If possible; remove the sender unit from the vehicle's fuel tank, this will make it easier to attach the nut securely back onto the standpipe
- Drill a $\Phi 6 \pm 0.2\text{mm}$ hole into the sender unit
- Remove the nut from the standpipe and feed it through the hole ensuring the rubber 'o' ring remains on the standpipe 'head' side
- Replace the nut on the standpipe to secure it safely to the sender unit.
- Replace the sender unit into the fuel tank.

The bottom of the fuel standpipe should be 30-40mm from the bottom of the fuel tank to allow enough suction of fuel and at the same time not allow impurities and sediment to be drawn up the standpipe.

BISON 2000A Wiring Diagram – Brushless Version

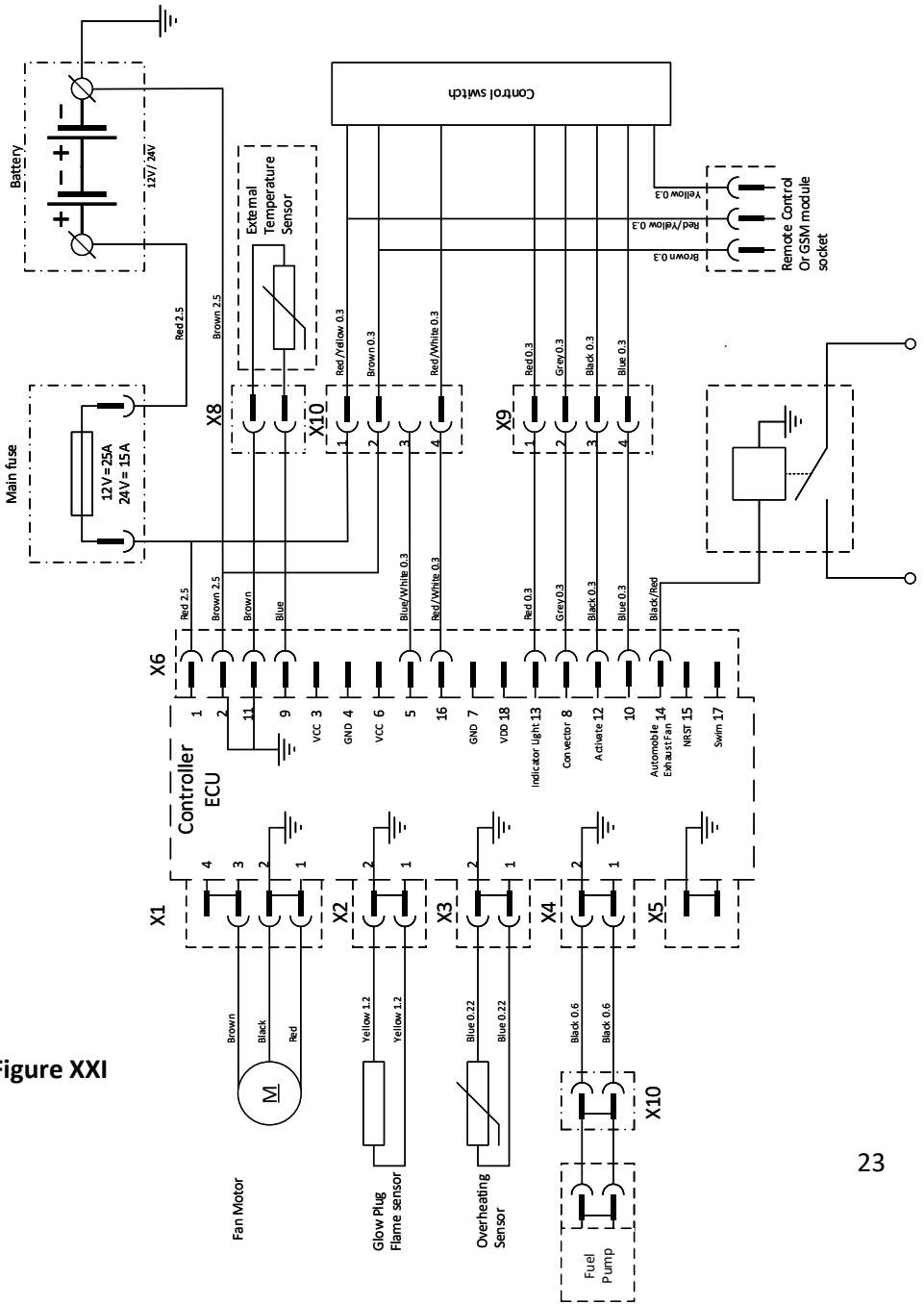

The previous page shows the wiring diagram for the heater.

The wires of the main heater have been made into bundles. They can be laid according to the positions of various components and should be fixed to the proper locations. The distance between two fixing points should not exceed 300mm.

Note: Any exposed wire outside the vehicle should be protected so as not to be ripped by any road debris or similar.

Connect the main wiring harness to the heater by gently removing the junction box cover. Connect the 12-wire connector of the main wiring harness to the controller socket (X7). The main harness can exit the heater to the left or to the right. Then replace the cover ensuring a good seal is kept all the way round. A fuse will already be inserted into the fuse holder (20A for 12V heaters and 15A for 24V versions).

Connect the 2.5mm² red wire and the 2.5mm² brown wire in the wire harness to the spring terminals and then to the positive and negative of the vehicles battery.

Straighten the fuel pump leads (two 0.6mm² black wires) and put them through the opening on the wall of the air inlet pipe. They can then be connected via the spring plug straight to the fuel pump or using the fuel pump extension loom if more length is required.

Timer and Rheostat Control Plugs

Use a single screw to fix the timer control or rheostat control in place. They are best installed so that they can be seen and operated easily to identify working conditions and for easy access. The black and clear plugs connect to the corresponding plugs on the loom (below). The remaining three-pin socket on the timer or rheostat control plugs into the remote-control receiver if one is installed. An adaptor cable may be necessary.

Timer Control Plug

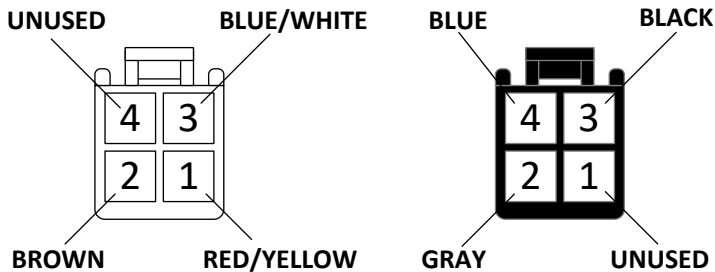

To Timer Control
 Figure XXII

Rheostat Control Plug

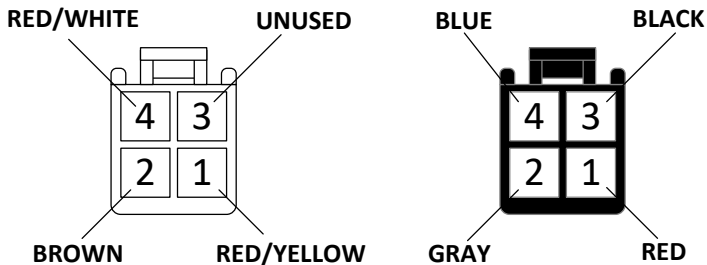

To Rheostat Control
 Figure XXIII

Wiring Loom Plug for Timer and Rotary Control

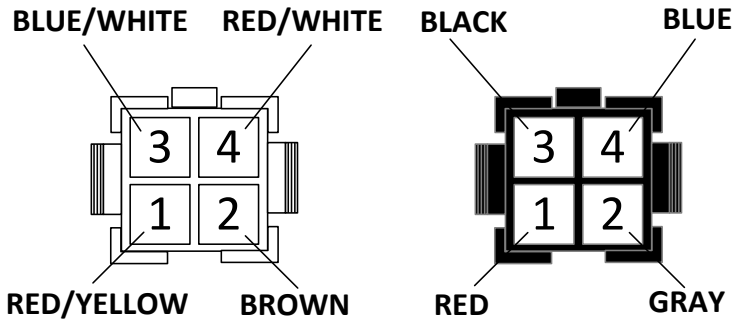

To Main Wiring Harness

Figure XXIV

Any surplus wires should be kept in good condition and wrapped in electric tape to avoid short circuiting.

External Remote Temperature Sensor Probe

The remote temperature sensor probe is best installed at shoulder height whilst sat down, ensuring ample air flow and a clear ambient temperature reading

It is inserted into the corresponding blue and brown wire plug just off from the main E.C.U. connection X6.

Circuit Interfaces

The connection parts on the controller case are designed in such a way that wrong connections are impossible to make.

The following circuit interfaces can be found on the controller case; these are:

- X1: Fan motor
- X2: Glow plug
- X3: Overheat sensor
- X4: Leads to fuel pump
- X5: Unused
- X6: Main Wiring Harness

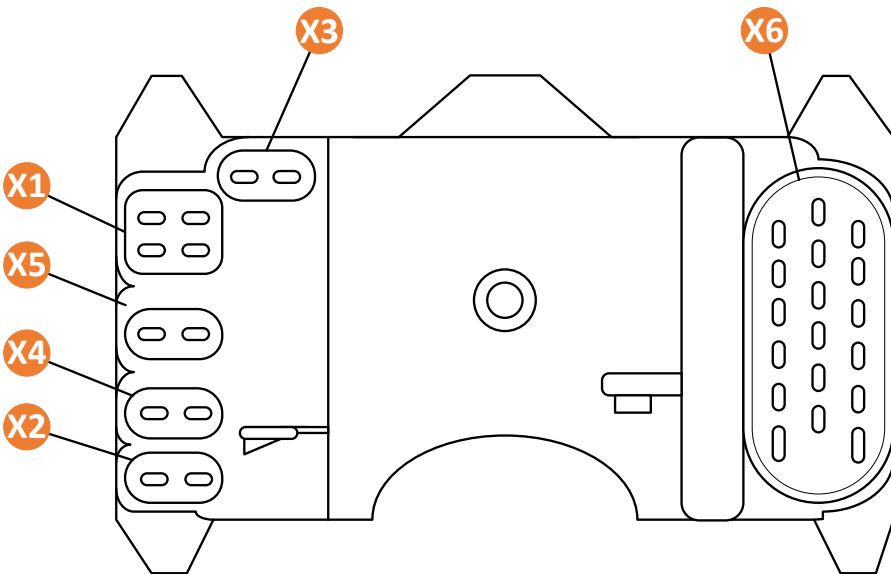
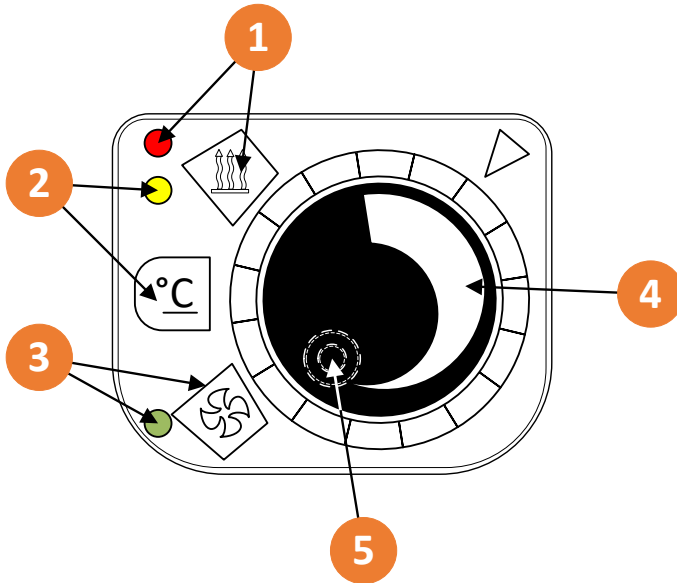

Figure XXV

Operation

Rheostat Control



1. Variable Output Button and Indicator Light
2. Temperature Button and Indicator Light
3. Fan Only (Cold Air) Button and Indicator Light
4. Control Knob
5. Fixing Screw Hole (Located underneath control knob)

Figure XXVI

The rheostat (or rotary) control works by twisting the control knob to the desired heat setting, and using the buttons listed to determine the heaters function. Variable output is simply high to low heat. The temperature button switches the heater to thermostatic mode (the heater will then switch to a cool-down cycle automatically once it has reached the selected temperature). The fan button only switches the fan on for cool air.

Mini Timer

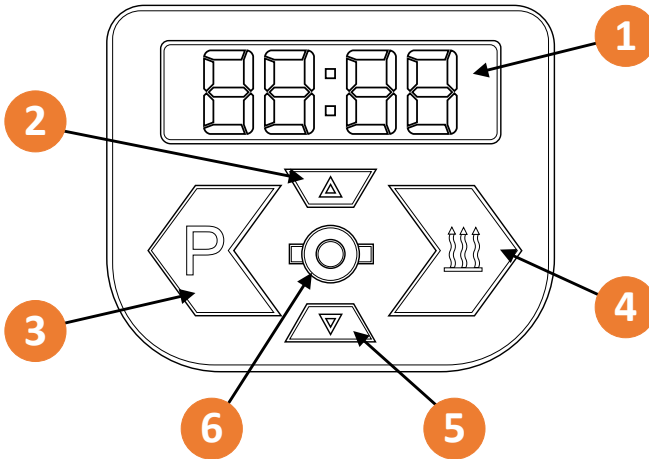

- | | | |
|-------------------|-------------------|----------------------|
| 1. Display | 2. Up Arrow Key | 3. 'P' Icon |
| 4. 'Heating' Icon | 5. Down Arrow Key | 6. Fixing Screw Hole |

Figure XXVII

Functions

- Adjustable thermostatic mode from 5°C to 35°C
- Adjustable 7 step heating mode from <1kW to your heaters full output
- 24-hour countdown set up time
- Heating time from 15 minutes to 99 hours
- Fault Information Codes

Manual Start Up and Shut Down

For immediate start-up press the heating icon to change the standby mode into the heating mode and the heater will start up immediately.

To adjust the heating temperature in the heating mode simply press the up or down arrow keys.

To turn the heater off manually, simply re-press the heating icon.

Pre-setting Heating Time

During heating mode, press the 'P' button and the down arrow simultaneously to start a countdown for the heating time.

Adjust the hour with the arrow keys and confirm the time with the 'P' button. Then adjust the minute time again using the arrow keys and confirm again with the 'P' button.

Note: The 'dot' in the upper right hand corner of the screen means the time was set successfully. To cancel press the heating icon.

Pre-setting Starting and Heating Times

Step 1: Press the 'P' key in the standby mode to enter the pre-set mode.

Step 2: The time mode will appear. Adjust the hour first with the arrow keys and press the 'P' when complete to move onto the minutes. You can adjust the minutes in the same way, however ensure you press the 'heating icon' to confirm (the confirmation dot will appear in the upper right hand corner of the screen), then press the 'P' button to move onto the next step

Step 3: Next stage is the temperature/output stage, the two can be adjusted by pressing the arrow keys simultaneously. The modes can then be adjusted with the arrow keys. Once adjusted; confirm the selection by pressing the 'heating icon' and move onto the next step by pressing the 'P' button.

Step 4: Next step is adjusting the heating time. You can adjust this in the same way using the arrow keys. The hour first followed by the minutes, pressing the 'heating icon' again to confirm and the 'P' key for the final time to complete the task.

Note: The 'confirmation dot' in the upper right hand corner of the screen must be present each time a step is adjusted to confirm it.

Checking Temperature

Pressing the 'P' and 'up' arrow button simultaneously whilst in the heating mode will display the air inlet temperature, or the remote temperature sensor probe's temperature if one is fitted.

Note:

- The display will show 0°C if the temperature is lower than 0°C
- The display will automatically revert to the heating mode if left idle for more than 5 seconds

Converting to Thermostatic Mode

Press both arrow keys to manually change from the heating mode to the thermostatic mode.

Fault Information

The fault display can be accessed by pressing the 'P' button during the heating mode.

Six fault codes can be checked by pressing the arrow keys.

To return to the heating mode, press the heating button.

To eliminate the fault information; press the 'P' and heating buttons simultaneously.

Remote Operation

When the remote signal had been received, the timer will automatically switch to the thermostatic mode, with a default temperature of 25°C, the confirmation dot will appear in the meantime.

To return to the standby mode, press the heating icon. The confirmation dot will continue to appear until the remote shutdown signal has been received.

Installation Fuel Priming Feature

ATTENTION:

- Not to be used in normal heater operation
- Disconnect the fuel line from the heater first, to prevent flooding of the heater and place in a suitable receptacle.

To enter the fuel priming mode, press and hold the 'P' icon for more than three seconds and let go to enter the next step.

Next, press and hold the heating icon for more than three seconds and then let go. If done correctly the display will read 'FUEL' and the pump will begin to pump quickly. To stop; press the heating icon again.

Press and hold the 'P' icon for more than three seconds to return to the standby mode.

LCD Digital 7-Day Timer

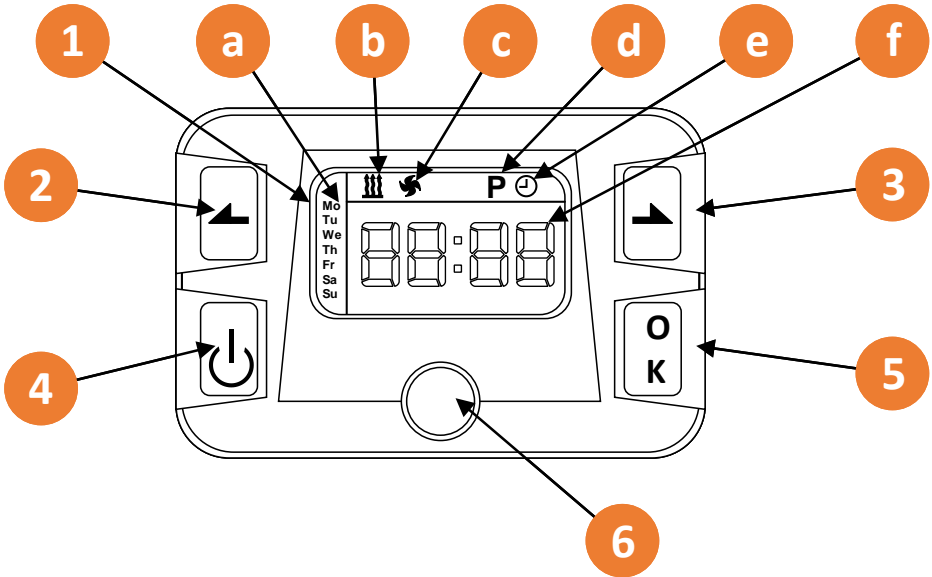

Figure XXVIII

- | | |
|-----------------------|-----------------------------------|
| 1. LCD Screen | a. Days of the week |
| 2. Left Arrow Button | b. Heating Symbol |
| 3. Right Arrow Button | c. Fan Symbol (later models only) |
| 4. Power/Back Button | d. 'P' (Timer) Symbol |
| 5. OK Button | e. Clock Symbol |
| 6. Fixing Screw Hole | f. Clock Face |

Functions:

- 7 day timer, able to be programmed 3 times daily
- 7 step variable output mode
- Thermostatic mode from 05°C to 35°C
- Adjustable cold air fan mode (on later versions)

Changing Language

The language should be set to English. However, if it isn't or the control has been reset to default settings it will revert to Chinese. Please follow these steps to convert the language to English.

1. Turn on the control with the power button. Wait for the symbols to stop flashing, then press the power button again.

2. Navigate to the clock face symbol at the top of the control by using the arrow keys. When it is flashing press both arrow keys simultaneously.

3. P1 now appears.

4. Press ok and C1 will appear.

5. Keep pressing ok slowly until '02:oF' appears.

6. Press any of the arrow keys until the screen reads '02:on'

7. Keep pressing ok until back to the P1 menu screen

8. Press power button to return. The language will now be set to English.

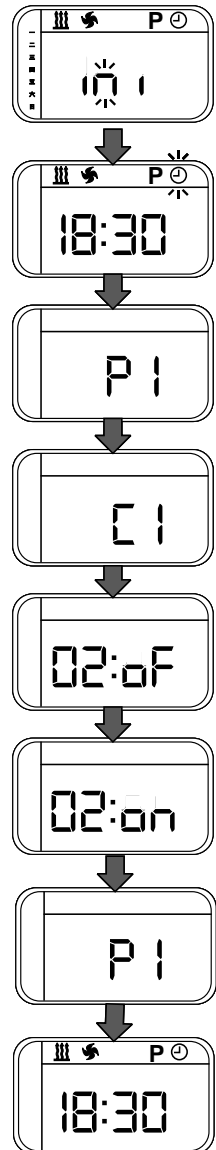

Changing the Date and Time

1. To change the date and time, navigate to the clock face symbol and press ok.
2. Select the day of the week it is first using the arrow keys, and pressing ok to confirm.
3. Select the hour using the arrow keys, and pressing ok to confirm.
4. Finally, select the minutes in the same way.
5. Once completed, the control will return to the home screen (displaying the correct time)

NOTE: If the LCD digital timer is disconnected from the loom, the date and time will need to be re-entered.

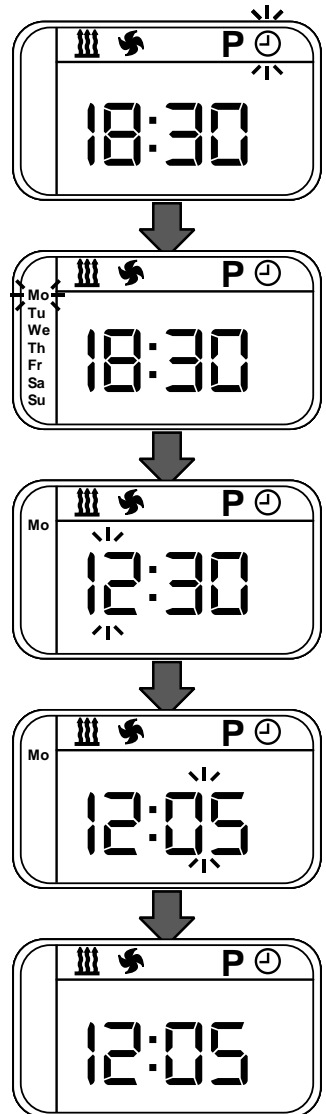

Manual On/Off

1. To switch the power on manually, navigate to the heating icon, and press ok
2. The heater will start automatically.
3. Use the arrow keys to adjust the output of the heater from high to low (07 to 01 respectively)
4. To switch the heater off, simply press the heater button to return to the home screen.

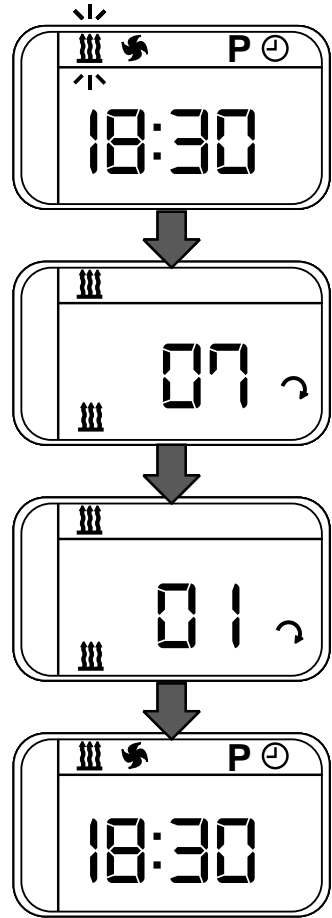

Switching to Thermostatic Mode

To switch to thermostatic mode, turn the heater on manually, as stated in the previous step.

1. Once the heater is on, press and hold the ok button for three seconds and then release it.
2. The display should change to a temperature setting which can be adjusted from 05°C to 35°C using the arrow keys.
3. To adjust back to the variable output mode, simply press and hold the ok button again for 3 seconds and then release it.
4. To switch the heater off, press the power button to return to the home screen.

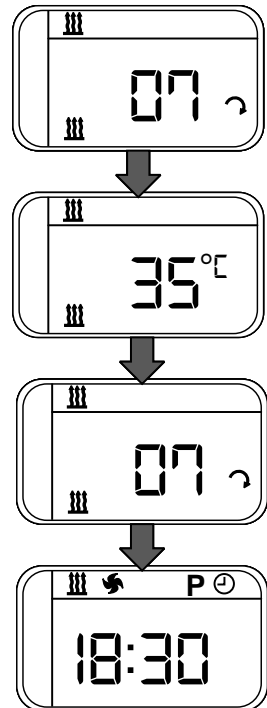

Fan Mode

The fan mode works in the same way as the manual on/off mode. Simply navigate across to the fan symbol and confirm with OK. The fan will then automatically switch on and its speed can be adjusted from high to low (07 to 01 respectively) using the arrow keys. To switch it off, press the power button.

NOTE: Some earlier models will not have this function.

Pre-setting Heating Times

The digital control can be used as a 7-Day timer, and is able to be preset to switch on up to three times a day.

1. Navigate to the 'P' symbol, and press OK.
2. Using the arrow keys select the number 1 (flashing) at the top of the screen, and press OK – Number 1 is the first heating time.
3. Using the arrow keys, select 'ON', as this will allow the heater to switch on after the presetting is finished. Press OK to confirm.
4. Select the length of time you want the heater to run for by using the arrow keys. – L800 represents 800 minutes. Run time can be selected from 50-990. Press OK to confirm.
5. Select the hour you wish the heater to start at by using the arrow keys and then pressing OK to confirm.

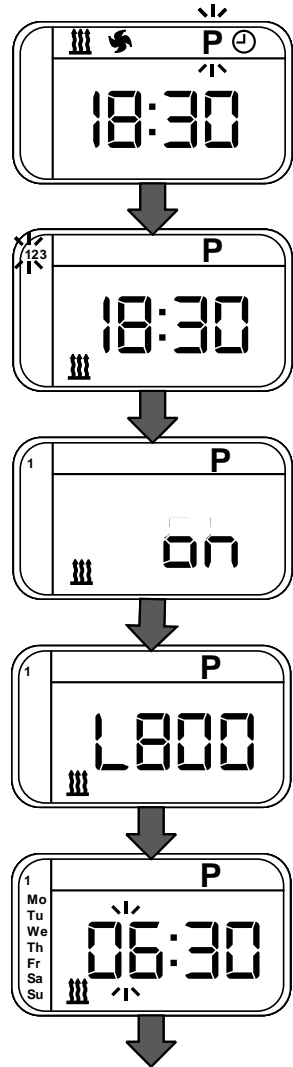

6. Select the minutes in the same way, and press OK to confirm.

7. The next step is choosing which day of the week you want the heater to run. Starting with Monday, use the arrow keys to change from 'OFF' to 'ON' and press OK to confirm. Continue this all the way through to Sunday.

8. The preset time should now be set. This will be indicated by the small, underlined number 1 at the top of the screen.

9. To set the second and third heating times, simply repeat all the steps but select 2 or 3 instead of 1 (see step 2.) to set those heating times.

NOTE: To turn any of the preset times off without altering the set times, simply go through to step 3 and select 'OFF' using the arrow keys. Then repeatedly press OK until you have returned to the home screen.

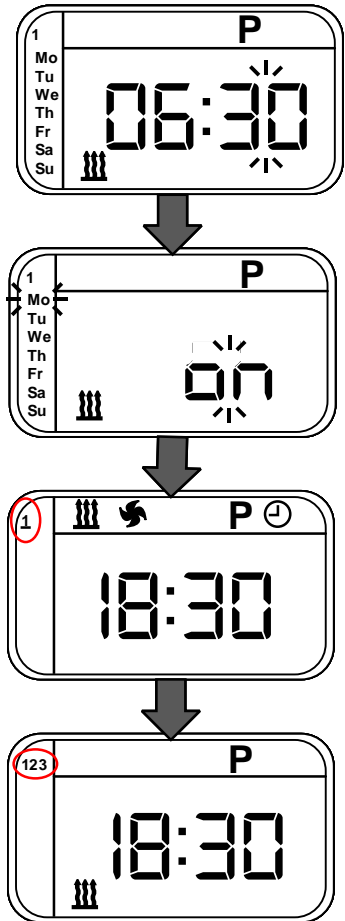

Installation Fuel Priming Feature

ATTENTION:

- Not to be used in normal heater operation
- Disconnect the fuel line from the heater first, to prevent flooding of the heater and place in a suitable receptacle.

1. To enter the fuel priming mode, navigate to the clock face using the arrow keys and press both arrow keys simultaneously.

2. P1 should appear on the screen.

3. Select P2 by pressing any arrow key, and confirm with OK.

4. The fuel pump will begin to rapidly pump the fuel.

5. It will automatically shut down after three minutes, or press any key to stop the pumping at any time, and return to the home screen.

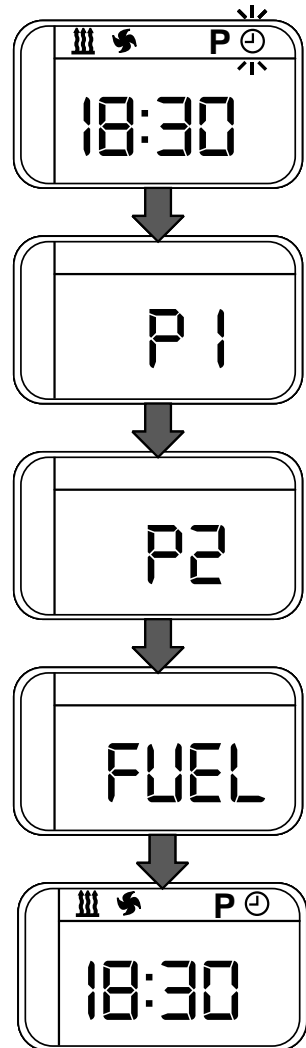

Checking Error Codes

Once an error code has been displayed, and the problem has been amended, follow these steps to reset it.

1. Check the error using the arrow keys. Exit by pressing either OK or the power button.
2. Press both arrow keys to display message 'dEL'.
3. Press OK to delete all errors or power to go back. Once the display reads 'IE 00' then no errors have been found.
4. Press OK or power to return.

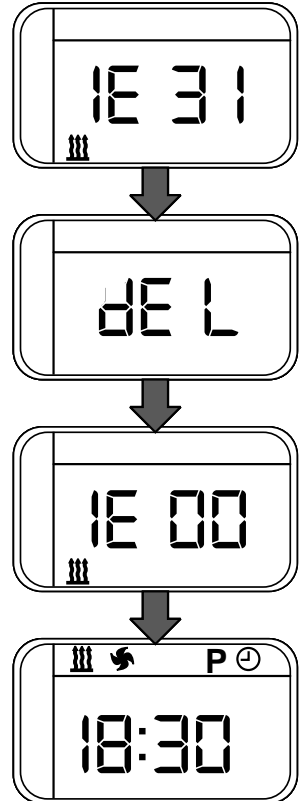

Resetting Digital Controller to Factory Settings

1. Navigate to the clock face on the menu and simultaneously press both arrow buttons.
2. P1 should appear on the screen.
3. Using the left arrow key select '—01', confirm by clicking the 'OK' button.
4. The control should now be reset to its original factory settings.

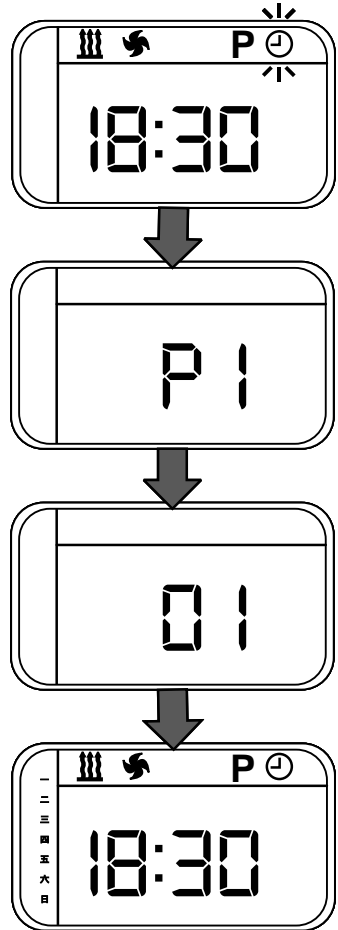

Maintenance

Once the heater is installed, it should ideally be turned on a few times to remove any air trapped in the fuel lines. Also ensure there is no leaking from the lines and that all electric terminals fit securely together.

You should also regularly:

- Check the air inlet and outlet for any pollution or foreign matters
- Clean the externals of the heater
- Check for corrosion or loose connections of the circuits
- Check the combustion air inlet and exhaust pipe for damage and clogs
- Check the fuel line for leaks

To ensure a long life of the heater it is advised that you run it for at least 10 minutes every month, to prevent malfunction of mechanical parts.

After 10 years the heat exchanger, overheat sensor and exhaust should be replaced by a professional.

If any welding is being attempted on the vehicle, please remove the positive power supply wire and earth it to protect the controller from any damage.

Fault Codes

Rheostat Control

When the ECU had discovered a fault, the rheostat control will flash a fault code. The control should therefore be ideally placed where it can be clearly seen and accessed.

The faults will be displayed as short flashes followed by long flashes. To determine the code, you must count the number of **long** flashes.

Number of Long Flashes	Cause of Problem
1	Failure of second start
2	Termination of the third time of combustion
3	Voltage power out of specified range
4	Glow plug temperature increases slowly
5	Air heaters will not flash 5 times
6	Temperature sensor: Broken circuit or short-circuit
7	Fuel pump: Broken circuit or short-circuit
8	Fan motor: Broken circuit, short-circuit or clogged
9	Glow pin: Broken circuit or short-circuit
10	Overheated
11	Overheat sensor: Broken circuit or short-circuit
12	Control switch: Broken circuit or short-circuit

Timers

1E-02 : Overheat – Check for obstruction or damaged ducting

1E-10 : Ignition failure – Check fuel supply, blocked supply or fuel pump

1E-30 : Voltage too high

1E-31 : Voltage too low – check battery or voltage drop in supply cable

1E-52 : Overheat sensor failure

1E-70 : Fuel pump open circuit or ECU failure

1E-80 : Air motor failure

1E-90 : Glow pin failure

1E-d3: Maintenance Reminder

Thank you for purchasing the BISON 2000A

